

V-2901A UNIVERSAL DOOR ANSWERING SYSTEM

INTRODUCTION

The V-2901A, Universal Door Answering System, when used with Valcom Doorplate Speakers, provides voice paging with handsfree reply to a door from any telephone location. The V-2901A initiates ring-in on the telephone system and sends a confirmation tone to the door speaker. The individual at the phone responding to the signal will determine if access should be allowed. Pressing a programmed code on the telephone dialpad or pressing the remote button will unlock the door to allow admission. The V-2901A also provides an alarm control output to alert an alarm system of an unauthorized entry.

These instructions contain the specifications and information necessary to install, operate and maintain the Universal Door Answering System.

FCC Notice

This equipment generates and uses radio frequency energy and if not installed and used properly, that is, in strict accordance with the instructions listed in this User's Manual, may cause interference to radio and television reception.

It has been tested and found to comply with the limits for a Class B Computing Device in accordance with the specifications in Subpart B of Part 15 of the FCC rules, which are designed to provide reasonable protection against such interference in a residential installation. If this equipment does cause interference to radio or television reception, which can be determined by turning off the equipment and seeing if the interference stops, the user is encouraged to try and correct the interference by one or more of the following measures:



- Reorient the receiving antenna.
- Relocate the equipment with respect to the radio or television.
- Move the equipment further away from the radio or television.
- Plug the equipment into a different branch circuit.

NOTE: The manufacturer is not responsible for any radio or TV interference caused by unauthorized modifications to this equipment. Such modifications could void the user's authority to operate the equipment.

SPECIFICATIONS

Access

- Electronic Key Systems
- PABXs
- 1A2 Key Systems
- Stand Alone Systems

Refer to Figure 1 for a simplified block diagram of a typical installation.

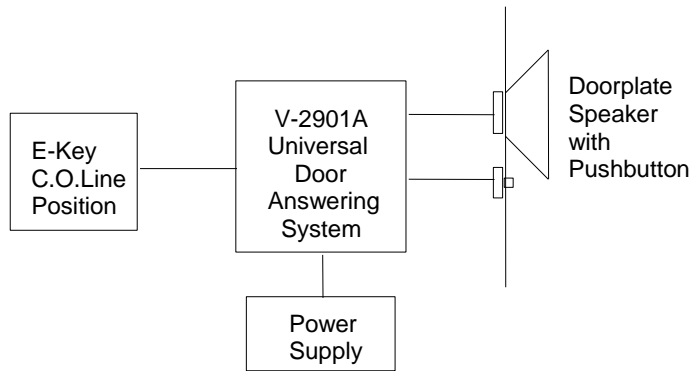

FIGURE 1
SIMPLIFIED BLOCK DIAGRAM OF A TYPICAL INSTALLATION

Features

- Compatible with PABX, E-Key and 1A2 telephone systems
- Switch selectable - loop or ground start access
- Provides handsfree talkback
- RJ11 modular connector for Tip and Ring connections
- Power ON LED
- Provides door unlock contacts
- Programmable options:
 - Programming access code
 - Ring pattern
 - Activate lock relay
 - Duration of lock relay activation
 - Time door can remain open after unlock (exit delay time)
 - Entry delay time
 - Duration of ringing
 - Disable station alarm
 - Alarm disable code
 - Station alert tone
- Input for manual door unlock (push-button)
- Built-in 30Hz ring voltage generator with on/off switch
- Ringback tone to speaker
- Calls can be placed On Hold
- Background music input with volume control
- Speaker to phone volume control
- Phone to speaker volume control
- Confirmation tone
- Compatible with tone dial phones
- Works with Valcom V-1072A doorplate speaker or other Valcom talkback or doorplate speakers
- Compatible with VPB-260 battery backup

Dimensions/Weight

- 8.60"H x 11.00"W x 2.30"D
(21.84cm H x 27.94cm W x 5.84cm D)
- 3.0 lbs. (1.36 kg)

Nominal Specifications

Input Impedance:	600 Ohms
Input Level:	-10dBm Nominal
Output Impedance:	45 Ohms
Ring Supply:	90VAC, 30Hz

Power Requirements

Power Supply:	-24VDC filtered 600mA minimum
---------------	----------------------------------

Environment

Temperature:	0 to +40°C
Humidity:	0 to 85% (non-precipitating)

Components

The following equipment is recommended when using the V-2901A:

- 1 - V-2901A Universal Door Answering System
- 1 - C. O. Line Position (Electronic Key System); or
- 1 - Loop Trunk Position (PABX); or
- 1 - 400 type line card (1A2 key)
- 1 - Dedicated single line phone*
- 1 - Valcom Doorplate Speaker**
- 1 - VP-624B Power Supply

*** A single line telephone cannot be connected to both the V-2901A and an incoming central office line.**

**** It is recommended that one talkback speaker be used. Use of more than one talkback speaker may result in damage to the V-2901A. Up to 40 one-way amplified speakers may be connected to the V-2901A speaker output.**

DESIGN

The V-2901A, Universal Door Answering System, was designed to provide voice paging with handsfree reply to a door speaker from a telephone location. The V-2901A initiates ring-in on the telephone system and sends a confirmation tone to the door when a button is pressed at the door (Valcom doorplate speakers are normally used in this application). The individual at the phone responding to the signal can converse with the person at the door and determine if access should be allowed. If the door is equipped with an electric strikeplate, the person at the phone can enter a programmed code on the telephone dialpad or press a remote button to unlock the door to allow admission. A call to the door may also be initiated from the telephone system.

The V-2901A provides an alarm control output for unauthorized entry. When the door lock relay is activated and the door remains open longer than the programmed period of time, a ground potential will appear on pin 3 of the V-2901A (unauthorized door opening) that can be used to signal a customer provided alarm, auto dialer, etc. Also, if the phone is on hook, the phone will begin ringing in a single burst pattern. If the phone is off hook, it will receive a momentary warble tone. After hang-up, if the door is not closed, the alarm condition will continue.

When indication arrives that a door is open while door station is inactive, such as a break-in, the system waits the programmed period of time (entry delay time) for a confirmation of entry indicating the opening as legitimate. When this does not arrive in the programmed time frame or if it arrives and the door is not closed at the end of the programmed time period, an alarm will sound in the same manner as described above.

The V-2901A also provides a background music input and is designed to automatically mute music during a page. If background music is to be installed, a low level music source such as the Valcom V-2952 FM Tuner will be required.

Applications for the V-2901A includes a doorway, gateway, window or secure room - just to name a few.

INSTALLATION

Cabling

A 25 pair cable with a female amphenol connector should be run from the V-2901A to a 66 block. The cables should be terminated on the connecting block in standard color code. Refer to Figure 2 - Block Connections for the pinout locations.

Mounting

The V-2901A is designed to be wall or shelf mounted. When wall mounting the V-2901A, secure the unit to wall studs or a suitable brace, away from heat sources or strong magnetic fields (motors, fans, power supplies, etc.) with controls and connectors accessible. (A plywood backboard two feet square and at least 1/2 inch thick attached to wall studs would be considered a suitable brace).

Four #10 x 3/4 inch flat-head wood screws are included for mounting. Fasten two screws on the mounting surface, allowing them to protrude 1/8 inch to 1/4 inch. Place the chassis of the V-2901A onto the screwheads at the mounting slots. Position the remaining screws and fasten through the remaining mounting slots. Tighten screws.

Connections

Mount a 66 block on the backboard near the V-2901A Universal Door Answering System and label the block per Figure 2.

Move slide switch SW2 on the V-2901A to the appropriate location, Loop or Ground Start, (see Figure 3) depending on how the V-2901A is accessed.

If a modular cord is used for Tip and Ring connections, start at step ONE. For 66 block connections start at step TWO.

- ___ 1. Connect one end of the modular cord to the V-2901A RJ11 and the other end to the appropriate line position of the phone system. Go to step 3.
- ___ 2. Connect Tip of the key system line position, loop or ground start trunk, to Pin 26 (W/BL) and Ring to Pin 1 (BL/W).
- ___ 3. Connect Tip of a 45 Ohm talkback speaker to pin 32 (R/O) and Ring to pin 7 (O/R).

- ___ 4. If using a door button with the talkback speaker, connect normally open, single pole push-button switch to Door Button connection pin 33 (R/G) and pin 9 (BR/R) Ground. (Figure 5 depicts the speaker/door button hookup).
- ___ 5. Move slide switch SW1 (located on the V-2901A board) to the ON position if the telephone system is to ring when the door button is pressed. (Refer to Figure 3 for location).
- ___ 6. Connect the -24VDC power supply. - 24VDC should be connected to pin 25 (S/V) and Ground connected to pin 50 (V/S). The power LED located on the V-2901A board should illuminate.

Battery Backup

A Valcom VPB-260 Battery Backup may be added to the system to provide power in case of power failure.

The VPB-260 plugs directly into the V-2901A. Figure 4 shows the appropriate connection. The VPB-260 should be allowed to charge for approximately 9 hours before operating the V-2901A.

The Valcom VPB-260 battery backup may be used as the sole supply of power to the V-2901A.

Remote Door Unlock Relay

Figure 6 shows the V-2901A contact arrangement available for electric strike plate operation.

Before connecting an electric lock to the V-2901A, consult the manufacturer instructions for the proper connecting arrangement.

Remote Push-button for Manual Door Release

A momentary, normally open, single-pole, single-throw switch can be connected to the system. Pinouts to the 66 block are shown in Figure 7. Refer to manufacturer instructions for proper connections. The remote button should be placed in an inconspicuous location to provide a more secure system.

NOTE: If the remote button does not respond, you have most likely entered a confirmation press. Any immediate additional presses will result in an alarm condition.

Handsfree Indicator ("Station Outputs")

The V-2901A supplies connections to allow a handsfree indicator to be connected to the system. During handsfree communication, pin 6 goes to -24VDC when connected as shown in Figure 8. Maximum current available is 50mA.

Door Sensor

When this contact is shorted (opening the door, gate etc) without a legitimate dialpad or remote key press opening, this will initiate an alarm condition. Refer to Figure 9 for typical connections.

Unauthorized Door Opening

During an alarm state, UDO (unauthorized door opening) goes to ground, to signal a customer provided alarm that an alarm condition exists. Refer to Figure 10 for typical connections.

Remote Signaling (Alerting Device)

The V-2901A supplies contacts to allow an alerting device to be connected to the system. These contacts follow the ringing cycle (except when using British Ring - see note page 8) and can be used to operate a remote signaling device such as a bell, buzzer or light. Refer to Figure 11 for a typical connection using these contacts.

Background Music Connections

Connect the low level (-10dBm nominal) output of a music source to pin 29 (W/BR) and pin 4 (BR/W) of the 66 block. Adjust output of the music source to a low level. Volume of the background music will be regulated by the music volume control of the V-2901A.

FIGURE 2 - BLOCK CONNECTIONS

Tip	W/BL	26
Ring	BL/W	1
Common Audible Make	W/O	27
Common Audible Stationary	O/W	2
Common Audible Break	W/GR	28
Unauthorized Door Opening	GR/W	3
Background Music Tip	W/BR	29
Background Music Ring	BR/W	4
Door Unlock Make	W/S	30
Door Unlock Stationary	S/W	5
Door Unlock Break	R/BL	31
Station	BL/R	6
Handsfree Speaker Tip	R/O	32
Handsfree Speaker Ring	O/R	7
Door Button	R/G	33
Remote	G/R	8
Door Sensor	R/BR	34
Ground	BR/R	9
Not Used	R/S	35
Not Used	S/R	10
Not Used	BK/BL	36
Not Used	BL/BK	11
Not Used	BK/O	37
Not Used	O/BK	12
Not Used	BK/G	38
Not Used	G/BK	13
Not Used	BK/BR	39
Not Used	BR/BK	14
Not Used	BK/S	40
Not Used	S/BK	15
Not Used	Y/BL	41
Not Used	BL/Y	16
Not Used	Y/O	42
Not Used	O/Y	17
Not Used	Y/G	43
Not Used	G/Y	18
Not Used	Y/BR	44
Not Used	BR/Y	19
Not Used	Y/S	45
Not Used	S/Y	20
Not Used	V/BL	46
Not Used	BL/V	21
Not Used	V/O	47
Not Used	O/V	22
Not Used	V/G	48
Not Used	G/V	23
Not Used	V/BR	49
Not Used	BR/V	24
Power Supply GND	V/S	50
Power Supply -24VDC	S/V	25

Figure 3 - Connector and Control Locations

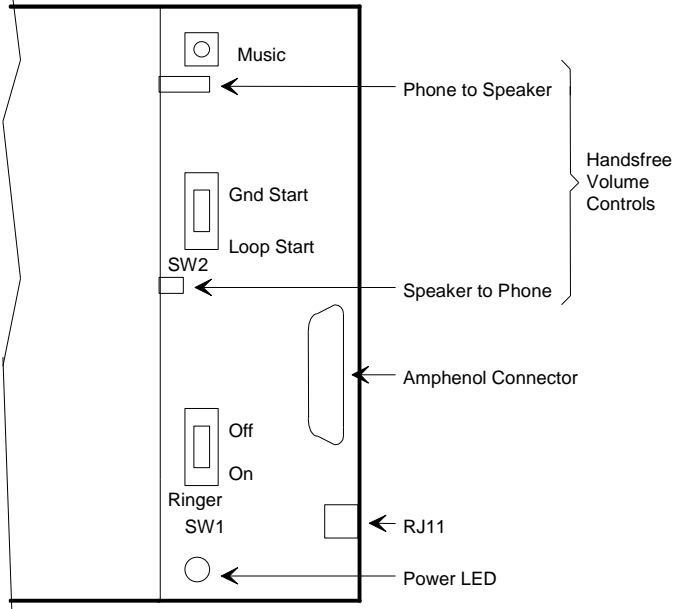
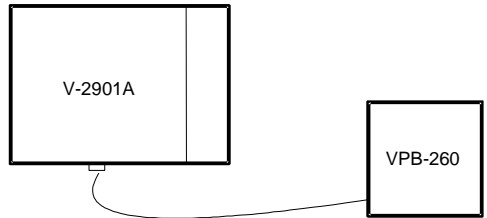

Figure 4 - Battery Backup



TYPICAL APPLICATIONS

Figure 5 - Doorplate Speaker with Pushbutton

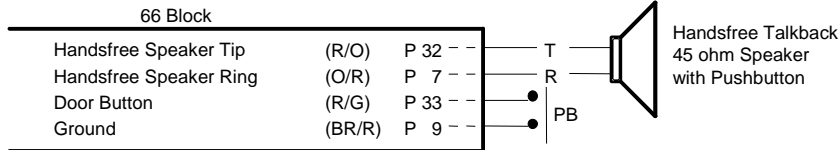
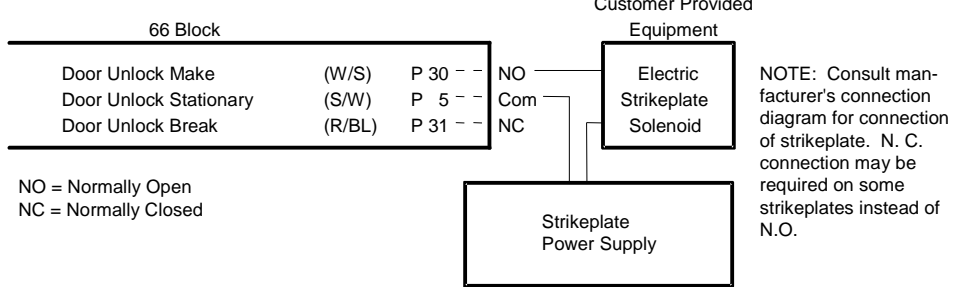

Figure 6 - Remote Door Unlock Relay



TYPICAL APPLICATIONS (Continued)

Figure 7 - Remote/Confirmation Pushbutton for Manual Door Release

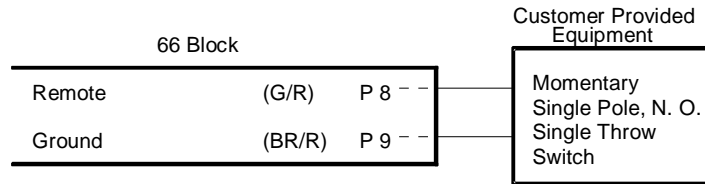

Figure 8 - Handsfree Indicator

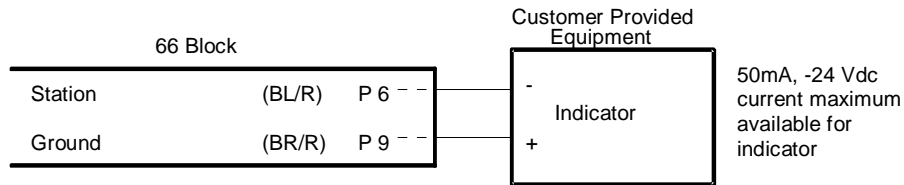

Figure 9 - Door Sensor

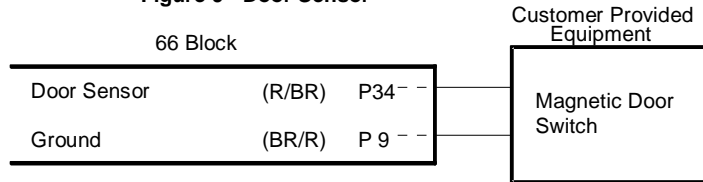

Figure 10 - Unauthorized Door Opening

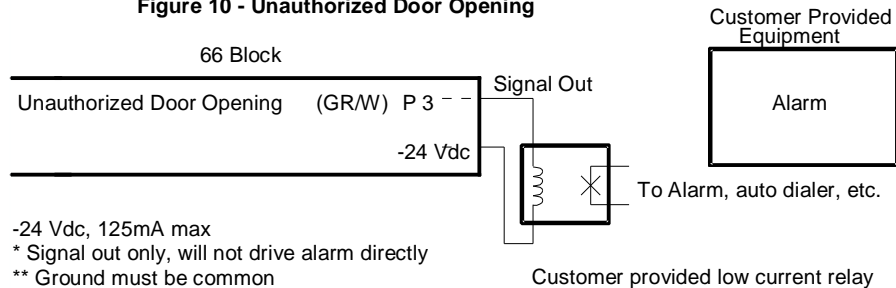
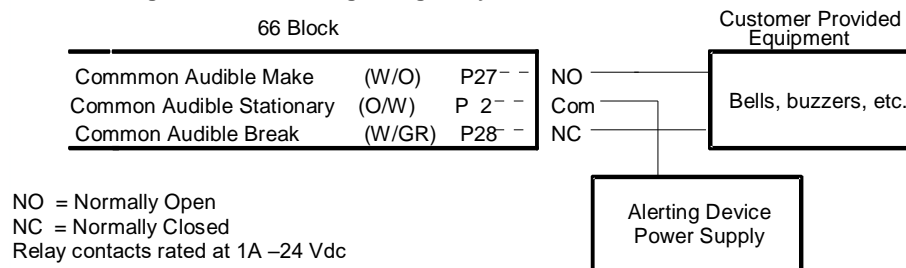

Figure 11 - Remote Signalling Relay



Volume Adjustments

There are four volume controls on the V-2901A. See Figure 3 for location of these controls.

- ___ 1. Phone to Speaker: Adjusts speaker volume.
- ___ 2. Speaker to Phone: Adjusts talkback volume from the speaker. **IMPORTANT:** Set this volume at the lowest practical level. Setting this control too high will increase background noise without giving greater talkback volume.
- ___ 3. Music: Adjusts Background Music volume at the door speaker.

PROGRAMMING

General

NOTE: The V-2901A can be accessed via tone dial systems and programming must be performed with a tone dial set.

The V-2901A is designed to allow the user to program its functions to meet the requirements of the specific application. The V-2901A is, however, shipped from the factory with the all functions pre-set to default settings. These default settings are listed in the Program Chart.

It is strongly recommended that the default settings be changed to suit the needs of the situation. The settings of the Access Code and Door Unlock Code, particularly, should be changed to provide a more secure system.

The following instructions explain the procedures to program the codes for the V-2901A. Individual codes can be programmed per feature. After each program change, a dial tone will be received designating a proper entry.

Master Access Code

The Master Access Code allows entry to programming as well as to the use of the system. **It is essential that this code remain confidential to maintain the security of the system. The Access Code can be 1 to 7 digits in length. The asterisk (*) or number (#) signs can not be used in the access code.**

The default master access code is 1 2 3. To change this code:

1. Lift handset, press # and hear dial tone.
2. Press # # # on the dialpad.
3. Enter the old access code on the dialpad.
4. Press * * * on the dialpad.
5. Enter the new access code on the dialpad.
6. Press * * * again.
7. Will receive dial tone if programmed correctly.

Programming Functions

The following program instructions show the access code for each function as 1 2 3. If a new master access code is programmed prior to programming the following functions, the new access code would be substituted where the 1 2 3 is shown.

These following codes cannot contain # as part of their code.

Ring Pattern

When the doorplate button at a station is pressed, the V-2901A initiates ring-in on the telephone system. There are three ring patterns available.

- 2 seconds on, 4 seconds off (American ring)
- 2 bursts in 2 seconds, 2 seconds off (British ring)
- 1 second on, 4 seconds off (Dutch ring)

To change the ring pattern:

American Ring (default)

1. Lift handset, press # and hear dial tone.
2. Press # 1 2 3 * 5 on the dialpad.
3. Receive dial tone.

British Ring

1. Lift handset, press # and hear dial tone.
2. Press # 1 2 3 * 6 on the dialpad.
3. Receive dial tone.

Dutch Ring

1. Lift handset, press # and hear dial tone.
2. Press # 1 2 3 * # on the dialpad.
3. Receive dial tone.

NOTE: The common audible relay contacts follow the ringing cadence with the exception of British Ring. In British Ring mode, the contacts close at the beginning of the first burst and remain closed until the end of the second burst.

Activate Lock Relay (Door Unlock)

This code would be used to operate the door unlock contacts which can be used to open an electric lock used at a doorway or gate. The default access code to activate the lock relay is *. This code can be from 1 to 7 digits and the asterisk (*) sign can be programmed in this code if desired.

To change this code:

1. Lift handset, dial # to hear dial tone.
2. Press # 1 2 3 # on the dialpad.
3. Press 1.
4. Enter up to 7 digits.
5. Press #.
6. Receive dial tone.

Duration of Lock Relay Activation

This function determines the length of time the lock relay remains activated after dialing the door unlock code. The default equals two seconds. The length of time the lock relay remains activated can be from one to 99 seconds depending on the specific situation. However, once an opening and closing of a door takes place, the unlock relay will release prior to the expiration of the programmed period preventing further entries.

To change this default setting:

1. Lift handset, dial # to hear dial tone.
2. Press # 1 2 3 # 6 on the dialpad.
3. Enter the number of seconds the lock should remain activated (1-99).
4. Press #.
5. Receive dial tone.

Time Door May Remain Open after Unlock before Alarm (this period of time also sets the exit delay time)

The length of time the door or gate should remain open will vary depending on the actual application. A drive-through gate may require a longer time than a walk-through door. If, for some reason, the opening does not close by the designated period of time, an alarm condition will occur (see Operation). The possible programmed time for a door to remain open can be from 0 to 999 seconds. The default for this function is 15 seconds. This default is changed by:

1. Lift handset, press # to hear dial tone.
2. Press # 1 2 3 # 7 on the dial pad.
3. Enter the number of seconds the door should remain open (0-999).
4. Press #.
5. Hear dial tone.

Entry Delay Time

If a key entry occurs at the door (an entry not using the dialpad or remote button), the remote button must be pressed or the confirmation code must be dialed on the telephone keypad within a designated period of time after the door is opened, signifying a legitimate door opening, or the V-2901A will go into alarm mode. The default time for the confirmation press is 15 seconds. This time can be changed by:

1. Lift handset, press # to hear dial tone.
2. Press # 1 2 3 # 8.
3. Enter time length in seconds (0-999).
4. Press #.
5. Receive dial tone.

Duration of Ring

When the door button is pressed, it activates the phone into a ring cycle. The ring cycle will continue for a programmed duration and stop if unanswered.

The default equals 30 seconds. To change this default:

1. Lift handset, press # receive dial tone.
2. Press # 1 2 3 # 5.
3. Enter the duration of ringing desired (1 - 255 seconds; 0 = continuous).
4. Press #.
5. Receive dial tone.

Disable Station Alarm

On power up, the station alarm condition is active. In the event a doorway or gate would need to be left open for an extended time (or at least longer than the programmed time it can remain open before an alarm condition), the alarm can be disabled.

To leave door open without causing an alarm condition:

1. Lift handset, press # and receive dial tone.
2. Press 5.
3. Enter disable code (default is *; this may have been changed - see below).
4. Receive dial tone.

The default code for disabling the station alarm condition is *. To change this default:

1. Lift handset, press # and hear dial tone.
2. Press # 1 2 3 #.
3. Enter up to 7 digits.
4. Press #.
5. Receive dial tone.

NOTE: When the station is disabled and then accessed, the alert tone will be at a lower pitch as a reminder that the station alarm has been disabled.

To enable the door alarm after it has been disabled:

1. Lift handset, press # to receive dial tone.
2. Press 6.
3. Receive dial tone.

Alert Tone

The phone and station receives a ringback tone prior to connection. Default the station receives the tone.

To remove the alert tone:

1. Lift handset, press # and receive dial tone.
2. Press # 1 2 3 # 9.
3. Press 0.
4. Press #.
5. Receive dial tone.

To re-activate the alert tone:

1. Lift handset, press # and receive dial tone.
2. Press # 1 2 3 # 9.
3. Press 1.
4. Press #.
5. Receive dial tone.

Door Detect

Some door alarm contacts are closed when the door is closed and some are open when the door is closed.

By default, the V-2901A uses door alarm contacts that are open when the door is closed.

To change this default:

1. Lift handset, press # and hear dial tone.
2. Press # 1 2 3 # 0 1.
3. Press # and receive dial tone.

OPERATION

When the doorplate button is pressed, interrupted ring voltage from the V-2901A initiates ring-in on the telephone system and sends a confirmation tone to the door. When the phone is answered, the ringing is removed, the phone receives a ringback tone and is connected to the handsfree speaker.

If the door is equipped with an electric strikeplate, a code can be dialed from the phone to operate the relay used to unlock the door. The lock relay will remain open for a programmed period of time. A normally open, single-pole push-button switch can also be connected to the V-2901A to manually operate the door unlock relay. The lock relay will remain open as long as the remote button is held (maximum 99 seconds) plus the programmed period of time.

After the lock relay has closed, if the door remains open longer than the programmed time, and a customer supplied door sensor is provided, an alarm condition will occur. If on hook, the phone will begin ringing in a pattern indicating that the door has failed

to close and the UDO (Unauthorized Door Opening) output goes to ground. When answered, the phone will receive a momentary warble tone and will be connected to the station. After hang up, if the door is not closed, the alarm condition will continue.

When an indication arrives that the door is open while the door station is inactive, (example: a break-in) the system waits the programmed period of time for a confirmation of entry, if the confirmation of entry is not received, the unauthorized entry alarm will take place as described previously.

Confirmation of Entry

When a key entry is made (an entry not using the dialpad or remote button), either the remote button must be pressed (a confirmation press) within the programmed period of time after the door is opened or the telephone can be used to dial the appropriate confirmation of entry. To confirm an entry by phone, access the V-2901A and enter door unlock code.

A confirmation press or entering the unlock code via telephone to signify a legitimate door opening must take place before the programmed period of time ends or an alarm condition will occur.

NOTE: The remote button can be used for a confirmation press or to activate the lock relay (door unlock).

Exiting without Alarm Activation

1. Lift handset and enter door unlock code or press manual door unlock push-button.
2. Exit door within the programmed exit delay time.
Exit delay time equals time door unlock relay is activated after unlock.

Call Out from the Phone

The dedicated single line telephone, C.O. line position, loop or ground start trunk used with the V-2901A is dedicated to the door communications and to features accessed within the V-2901A system. The phone can be used to access the speaker station by going offhook or by accessing the C. O. line position or trunk port that is connected to the V-2901A. A ringback tone (optional) will be generated prior to connection to the station.

A telephone connection with the station can be terminated by hanging up or pressing the # sign.

TECHNICAL ASSISTANCE

When trouble is reported, make certain there are no broken connections leading to this system. Table 1 identifies some possible problems with solutions.

Assistance in troubleshooting is available from the factory. When calling, you should have a VOM and a telephone test set available and be calling from the job site. Call (540) 563-2000 and press 1 for Technical Support or visit our website at <http://www.valcom.com>.

VALCOM equipment is not field repairable. VALCOM maintains service facilities in Roanoke, VA. Should repairs be necessary, attach a tag to the unit clearly stating your company name, address, phone number, contact person and the nature of the problem. Send the unit to:

**Repair and Return Dept.
VALCOM, INC.
5614 Hollins Road
Roanoke, VA 24019-5056**

WARRANTY

Warranty information may be found on our website at www.valcom.com/warranty.

USER GUIDE

Function	Action
Unlock Door	Dial unlock code (or press remote push-button).
Disable Alarm	Dial # to receive dial tone, dial 5 and the alarm disable code.
Enable Alarm	Dial # to receive dial tone, dial 6.
Exiting with Alarm On	Access system and dial unlock code (or press remote push-button), then exit door within exit delay time.
Entering with Alarm On	Enter door, then dial door unlock code (or press remote push-button) within entry delay time.

**TABLE 1
TROUBLESHOOTING CHART**

PROBLEM	ACTION
<ul style="list-style-type: none"> No system operation; power LED not lit No system operation; power LED is lit 	<ul style="list-style-type: none"> Verify power from power supply. Verify that 25 pair connector is completely plugged into circuit board connector. Refer to the Connection section and verify all connections.
<ul style="list-style-type: none"> No paging at speaker 	<ul style="list-style-type: none"> Check doorplate speaker connections. Adjust phone to speaker volume.
<ul style="list-style-type: none"> Paging at speaker but no reply from speaker 	<ul style="list-style-type: none"> Adjust speaker to phone volume.
<ul style="list-style-type: none"> No system ringing when doorplate button is pressed 	<ul style="list-style-type: none"> Check ring ON/OFF switch.
<ul style="list-style-type: none"> Door unlock relay does not operate 	<ul style="list-style-type: none"> Check connections at block. Verify proper access code.
<ul style="list-style-type: none"> Door strike does not operate 	<ul style="list-style-type: none"> Do you have a power supply for your door strike? (See Figure 6).

PROGRAM CHART RECORD AND FILE IN A SECURE PLACE

FUNCTION	DEFAULT	REPROGRAM	PARAMETER	NEW PROGRAM
Master Access Code (MAC)	1 2 3	### # 1 2 3 * * * _____ * * *	7 digits excluding # and *	
Ring Pattern American Ring British Ring Dutch Ring	American Ring	## MAC * 5 ## MAC * 6 ## MAC * #		
Activate Lock Relay	*	## MAC #1 _____ #	7 digits including *	
Duration of Lock Relay Activation	2 sec	## MAC #6 _____ #	1-99 in seconds	
Time Door May Remain Open After Unlock Before Alert (Exit Delay Time)	15 sec	## MAC #7 _____ #	0-999 in seconds	
Entry Delay Time	15 sec	## MAC #8 _____ #	0-999 in seconds	
Duration of Ringing	30 sec	## MAC #5 _____ #	1-255 sec; 0 = continuous	
Alarm Disable Code	*	* * MAC *1 _____ #	7 Digits	
Alert Tone	ON	[OFF] ## MAC # 90 # [ON] ## MAC # 91 #	OFF or ON	
Door Detect Default		## MAC # 0 0	Door contact open when door is closed.	
Door Detect Reversed		## MAC # 0 1	Door contact closed when door is closed.	

INSTALLATION _____

INSTALLING COMPANY _____

INSTALLER _____ **DATE** _____

A proper programming sequence is followed by a dial tone.
An improper programming sequence is followed by a busy tone.