

V-9939A

MICROPHONE ADAPTOR

INTRODUCTION

These instructions provide identification, installation, connection, operation, and maintenance information for the V-9939A, Microphone Adaptor.

The V-9939A is a Microphone Adaptor designed to be used with Valcom paging equipment.

SPECIFICATIONS

Purpose

- Provides microphone access to Valcom one-way amplified speaker assemblies.

Applications

- Allows local paging access to a zone of one-way paging speakers.
- Allows paging access to stand alone systems.

Refer to Figure 1 for a block diagram of a typical installation.

Features

- 600 ohms balanced and 50,000 ohm inputs
- Works with most microphones with push to talk switches
- Built in microphone preamplifier
- Mounts at microphone location
- Provides a set of form "C" contacts
- May be connected to a selected zone of a multi-zone paging system
- Screw terminals for all connections

Capacity

Each V-9939A may be connected to one zone of a paging system.

Dimensions/Weight

- 7.1"H x 4.7"W x 2.1"D
(18.03 cm H x 11.94 cm W x 5.33 cm D)
0.7lbs. (32kg)



Power Requirements

-21.5 to -26 Vdc filtered "A" Battery, 40 ma. max

Environment

Temperature: 0 to 50 Degrees C
Humidity: 0 to 85% non-precipitating

Nominal Specifications

Input impedance	600 ohms balanced/ 50,000 ohms unbalanced
Output impedance	600 ohms
Output level	-10dbm nominal

SYSTEM DESIGN

Configuration

There are two basic ways the V-9939A Microphone adaptor may be used:

1. It may be used with a V-1094A and Valcom one-way amplified speaker assemblies as a stand alone paging system.

When using the V-9939A for access to a stand alone paging system, the following will be required:

- 1 V-9939A Microphone Adaptor
- 1-Microphone (push to talk)
- 1 V-1094A Booster Control

- Valcom one-way amplified speaker assemblies (type determined by job requirements)
- Power Supply (type determined by style and quantity of speakers - Consult the Valcom One-Way Paging VSP for more information)

2. By using the V-9939A with a V-1101A One Zone One-way Page Adaptor or a V-9937 One Zone Page Port Adaptor you may automatically disconnect the speakers of one zone from a multi-zone page adaptor and allow microphone access to that zone. These configurations will allow the microphone to override the telephone access.

NOTE: These will work only on a zone of ONE-WAY paging.

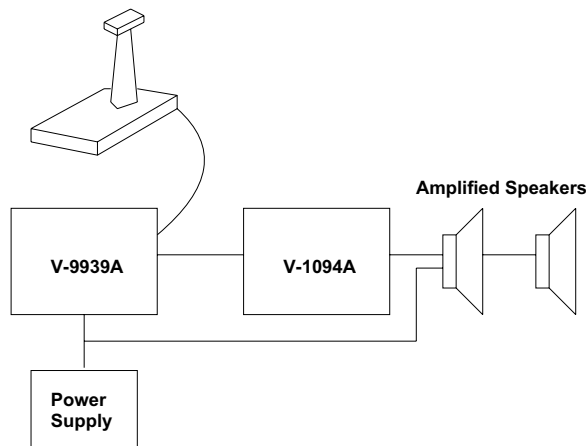

Figure 1 - Block Diagram of a Typical Installation

When using the V-9939A to override an existing zone of telephone accessed one-way paging, the following will be required:

- 1 V-9939A Microphone Adaptor
- 1-Microphone (push to talk)
- 1 V-1101A One Zone Page Adaptor
OR
- 1 V-9937 One Zone Page Port Adaptor
- An existing Valcom one-way page system

Other configurations are possible. Contact Technical Support {(540) 427-3900} with questions on specific applications.

Microphone Requirements

A standard high impedance (50,000 ohms) or low impedance balanced (600 ohms) microphone may be used. The microphone will be required to provide a dry contact closure (push to talk) for page access.

INSTALLATION

These instructions cover the installation procedures for the Valcom V-9939A and any associated Valcom equipment. Please consult practices for other manufacturer's equipment if any other equipment is being used. Refer to Figure 2 for location of screw connections. Refer to Figure 3 for screw connection designations.

The following sections contain step-by-step instructions for wiring the V-9939A and associated Valcom equipment. Each instruction is preceded by a line. Place a check on the appropriate line as the instruction is completed. The instructions also include tests along the way to verify connections have been made correctly. If these steps are followed exactly, installation of your Valcom system will go smoothly and quickly. If the results of a test do not correspond with what is shown, DO NOT PROCEED UNTIL THE PROBLEM HAS BEEN CORRECTED.

NOTE: During initial system setup it is recommended that all volume controls be set 1/2 turn clockwise.

Mounting

- Using two #6 3/4" wood screws, mount the unit in a convenient location near the microphone location

NOTE: DO NOT locate the V-9939A closer than 18" to a power supply or any equipment that generates electrical noise.

Power Connections

- ___ 1. Unplug power supply.
- ___ 2. Connect -24 Vdc "A" battery (may be referred to as "-" or "talk battery") from power supply to one of the PWR terminals on the V-9939A.
- ___ 3. Connect -24 Vdc Ground ("A" ground, "+" or "talk" ground) from power supply to the other power terminal. This GND should be properly grounded to an earth ground to alleviate hum on the system.

Connecting Arrangements

NOTE: Place a check by the Arrangement being used and proceed to the Figure indicated for step-by-step instructions.

- ___1. Stand alone page system: Proceed to Figure 4.
- ___2. Override an individual zone using a V-1101A: Proceed to Figure 5.
- ___3. Override an individual zone using a V-9937: Proceed to Figure 6.

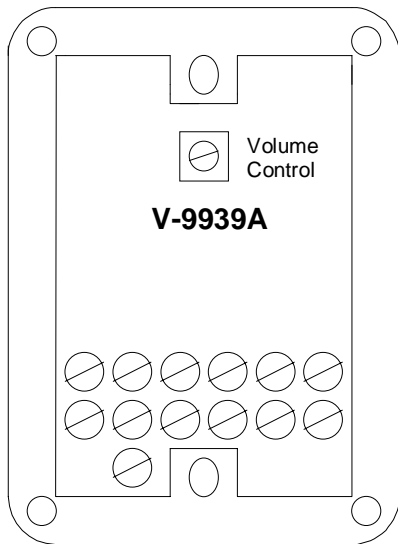

Figure 2 - Location of Screw and Volume

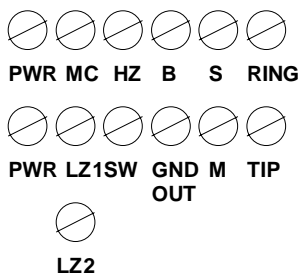

Figure 3 - Screw Connection Designations

WIRING INSTRUCTIONS (For Figure 4)

Place a check by each step as it is completed:

- ___1. Mount the V-1094A near the V-9939A or at the main frame.
- ___2. Connect Tip of the V-9939A to Tip of the V-1094A input.
- ___3. Connect Ring of the V-9939A to Ring of the V-1094A input.
- ___4. Connect Tip of the V-1094A output to the Tip side of all the one-way amplified speaker assemblies.
- ___5. Connect Ring of the V-1094A output to the Ring side of all the speakers.
- ___6. Connect the microphone:
 - ___a. Connect the audio common lead shield from the microphone to the MC terminal of the V-9939A. (This shield should be strapped to power supply GND).
 - ___b. Connect the other microphone audio lead to HZ if using a high impedance microphone; if using a low impedance balanced microphone, connect (+) lead to LZ1, and the (-) lead to LZ2.
 - ___c. Connect one side of the microphone push to talk switch to switch to the V-9939A SW terminal.
 - ___d. Connect the other side of the push to talk switch to the GND OUT terminal.
- ___7. Connect -24 Vdc from the power supply to the -24 Vdc terminal of the V-1094A.
- ___8. Connect Ground (+) of the power supply to the Ground terminal of the V-1094A.
- ___9. Connect -24 Vdc from the power supply to the -24 Vdc terminal (or the white lead) of each speaker assembly.
- ___10. Connect Ground of the power supply to the Ground terminal (or the black lead) of each speaker assembly.
- ___11. Plug in the power supply.
- ___12. Volume adjustment:
 - ___a. Set the V-1094A volume control to 5.
 - ___b. Turn the screwdriver adjustable volume control on the V-9939A about 1/2 of the way clockwise.
 - ___c. Verify all speaker controls are set at 1/2.
 - ___d. Speak through the microphone and adjust the V-1094A for the proper system level.
 - ___e. Speak through the microphone and adjust the individual speakers to the required levels.

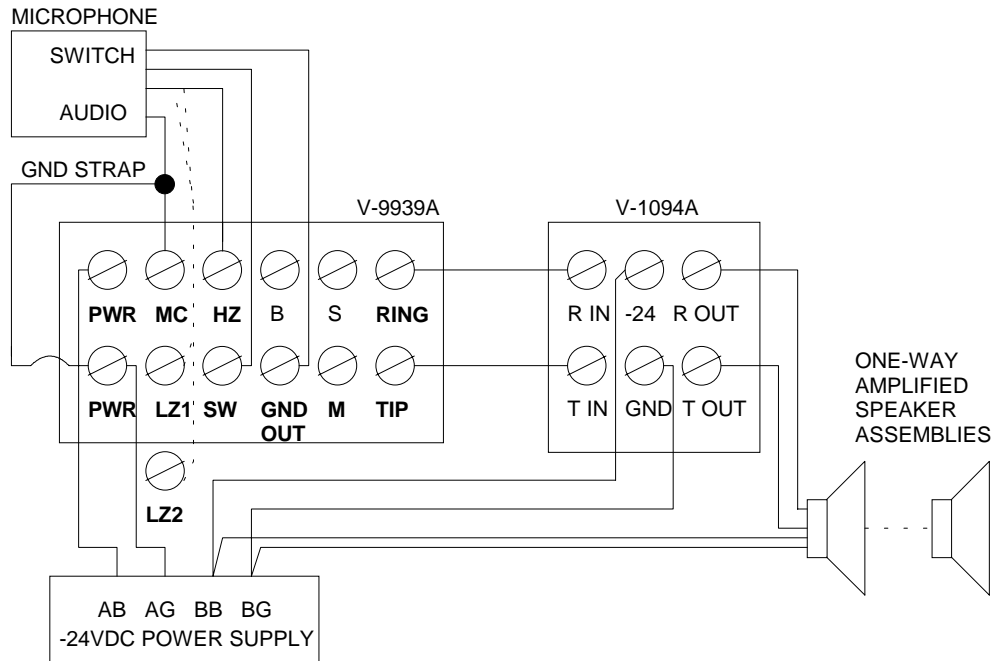

FIGURE 4 - STAND ALONE PAGE SYSTEM

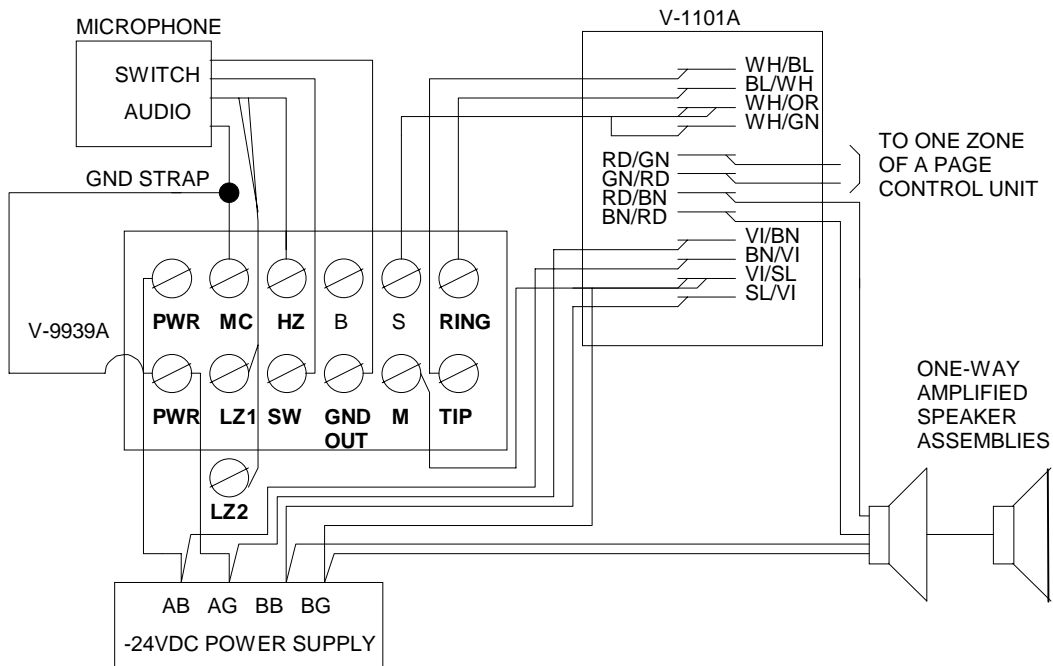

FIGURE 5 - OVERRIDE A SINGLE ZONE WITH A V-1101A

WIRING INSTRUCTIONS (For Figure 5)

Place a check by each step as it is completed:

- ___ 1. **IMPORTANT:** Complete installation and testing of your page control unit and speakers before adding the microphone adaptor.
- ___ 2. Mount the V-1101A near the microphone adaptor and connect it to a terminated 25 pair cable.
- ___ 3. Connect Tip of the V-9939A to Tip (white/blue) of the V-1101A.
- ___ 4. Connect Ring of the V-9939A to Ring (blue/white) of the V-1101A.
- ___ 5. Add a jumper on the V-1101A between the white/orange and the white/green.
- ___ 6. Connect the white/orange of the V-1101A to terminal S on the microphone adaptor.
- ___ 7. Connect the violet/slate of the V-1101A to terminal M of the microphone adaptor.
- ___ 8. Disconnect Tip of the audio pair to the speakers on the zone being overridden from the Page Control unit and connect it to the red/brown of the V-1101A.
- ___ 9. Disconnect Ring of the audio pair to the speakers from the Page Control unit and connect it to the brown/red of the V-1101A.
- ___ 10. Connect the red/green of the V-1101A to one side of the output pair from the page control unit for the zone to be overridden.
- ___ 11. Connect the green/red of the V-1101A to the other side of the output pair from the page unit for the zone being used.
- ___ 12. Connect the microphone:
 - ___ a. Connect the audio common lead shield of the microphone to the MC terminal of the V-9939A. This shield should be strapped to power supply GND.
 - ___ b. Connect the other microphone audio lead to HZ if using high impedance microphone; if using a low impedance balanced microphone, connect (+) lead to LZ1 and the (-) lead to LZ2.
 - ___ c. Connect one side of the microphone push to talk switch to the V-9939A SW terminal.
 - ___ d. Connect the other side of the push to talk switch to the GND OUT terminal.
- ___ 13. Connect -24 Vdc filtered talk battery from the power supply to the brown/violet of the V-1101A.
- ___ 14. Connect Ground (+) of the power supply to the violet/brown of the V-1101A.
- ___ 15. Connect -24 Vdc signal battery from the power supply to the slate/violet of the V-1101A.

- ___ 16. Connect signal ground of the power supply to the violet/slate of the V-1101A.
- ___ 17. Power Test
 - ___ a. Plug in the power supply.
 - ___ b. Momentarily short between the white/slate and slate/white of the V-1101A. If you hear a relay activate, then go to step 18.
 - ___ c. If you do not hear a relay, then unplug the power supply and go back to steps 13 to 16 and verify your connections.
- ___ 18. Volume adjustment:
 - ___ a. Turn the screwdriver adjustable volume control on the V-9939A about 1/2 of the way clockwise.
 - ___ b. Speak through the microphone and adjust the V-9939A screwdriver adjustment for the proper page level.

WIRING INSTRUCTIONS (For Figure 6)

Place a check by each step as it is completed:

- ___ 1. **IMPORTANT:** Complete installation and testing of your page control unit and speakers before adding the microphone adaptor.
- ___ 2. Mount the V-9937 near the microphone adaptor.
- ___ 3. Connect Tip of the V-9939A to pin 2 of the V-9937.
- ___ 4. Connect Ring of the V-9939A to pin 17 of the V-9937.
- ___ 5. Connect terminal S of the V-9939A to pin 3 of the V-9937.
- ___ 6. Connect terminal M of the V-9939A to pin 18 of the V-9937.
- ___ 7. Disconnect Tip of the audio pair to the speakers on the zone being overridden from the Page Control unit and connect it to pin 7 of the V-9937.
- ___ 8. Disconnect Ring of the audio pair to the speakers from the Page Control Unit and connect it to pin 22 of the V-9937.
- ___ 9. Connect pin 4 of the V-9937 to one side of the output pair from the page control unit for the zone being overridden.
- ___ 10. Connect pin 19 of the V-9937 to the other side of the output pair from the page control unit for the zone being overridden.
- ___ 11. Connect the microphone:
 - ___ a. Connect the audio common lead shield of the microphone to the MC terminal of the V-9939A. This shield should be strapped to power supply GND.
 - ___ b. Connect the other microphone audio lead to HZ if using a high impedance

- microphone: if using a low impedance balanced microphone, connect (+) lead to LZ1 and the (-) lead to LZ2.
- ___c. Connect one side of the microphone push to talk switch to the V-9939A SW terminal.
 - ___d. Connect the other side of the push to talk switch to the GND OUT terminal.
- ___12. Connect -24 Vdc (BB) signal battery from the power supply to pin 30 of the V-9937.
 - ___13. Connect signal ground (BG) of the power supply to pin 29 of the V-9937.
- ___14. Volume adjustment:
 - ___a. During initial system set up, set the screwdriver adjustable volume control on the V-9939A 1/2 turn clockwise.
 - ___b. Speak through the microphone and adjust the screwdriver adjustable volume controls on the V-9939A and output 1 of the V-9937 to the desired page level.
 - ___c. Access zone through the telephone system; adjust input 3 volume control on the V-9937 for the desired page level.

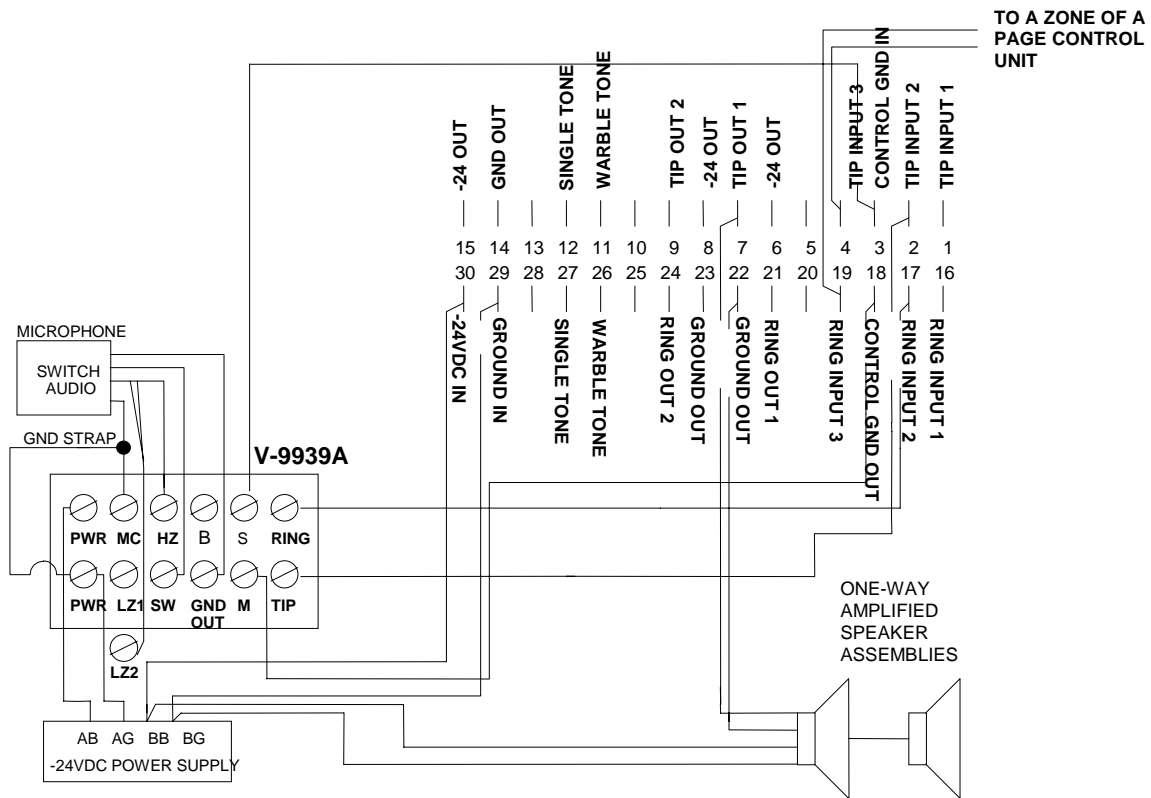

FIGURE 6 - OVERRIDE A SINGLE ZONE WITH A V-9937

OPERATION

Circuit Description

The V-9939A Microphone Adaptor has inputs for both high impedance and balanced low impedance microphones. It also has an input for a push to talk contact closure. When the closure is applied, a high gain pre-amplifier is turned on and the output relay is activated. The unit will stay active until the contact closure is removed. The preamplifier circuit also contains a voice limiting circuit to limit extremely loud inputs.

TECHNICAL ASSISTANCE

When trouble is reported, verify that power is being supplied to the unit and there are no broken connections. Check voltages for proper polarity on the crossconnect block.

Table 1 identifies symptoms of some possible problems with solutions. If a spare unit is available, continue to troubleshoot by substituting the spare unit for the suspected defective unit.

Assistance in troubleshooting is available from the factory. When calling, you should have a VOM and a test set available and be calling from the job site. Call (540) 427-3900 and ask for Technical Support, or call (540) 427-6000 for Valcom 24-hour Automated Support or visit our website at <http://www.valcom.com>.

The V-9939A is not field repairable. **Valcom equipment contains no user serviceable parts inside.** Valcom, Inc. maintains service facilities in Roanoke, VA. Should repairs be necessary, attach a tag to the unit clearly stating your company name, address, phone number, and contact person; and the nature of the problem.

Send the unit to:

**Valcom, Inc.
Repair and Return Dept.
5614 Hollins Road
Roanoke, VA 24019-5056**

TABLE 1 - TROUBLESHOOTING CHART

SYMPTOM	SOLUTION
1. No relay operation in V-9939A when microphone talk button is pressed.	Check for -24 VDC at V-9939A across the PWR terminals. Verify connection from microphone to terminals SW and GND OUT (refer to the Installation section).
2. Relay operation but no output.	Verify connections from microphone to MC and HZ or LZ terminals. Turn volume control up (clockwise).
3. Audio from V-9939A but not from V-1094A.	Verify Tip and Ring connections from V-9939A to V-1094A. Verify proper voltage and polarity at -24 VDC and GND terminals of V-1094A. Turn up volume at V-1094A.
4. No output from V-1101A.	Recheck all connections per Figure 5. Make sure the V-1101A passes the power test in Figure 5, step 17.
5. Output from V-9939A and V-1094A or V-1101A but not from speakers.	Verify proper voltage and polarity to speakers. Verify audio connections to speakers. Verify speakers are Valcom one-way amplified speaker assemblies.

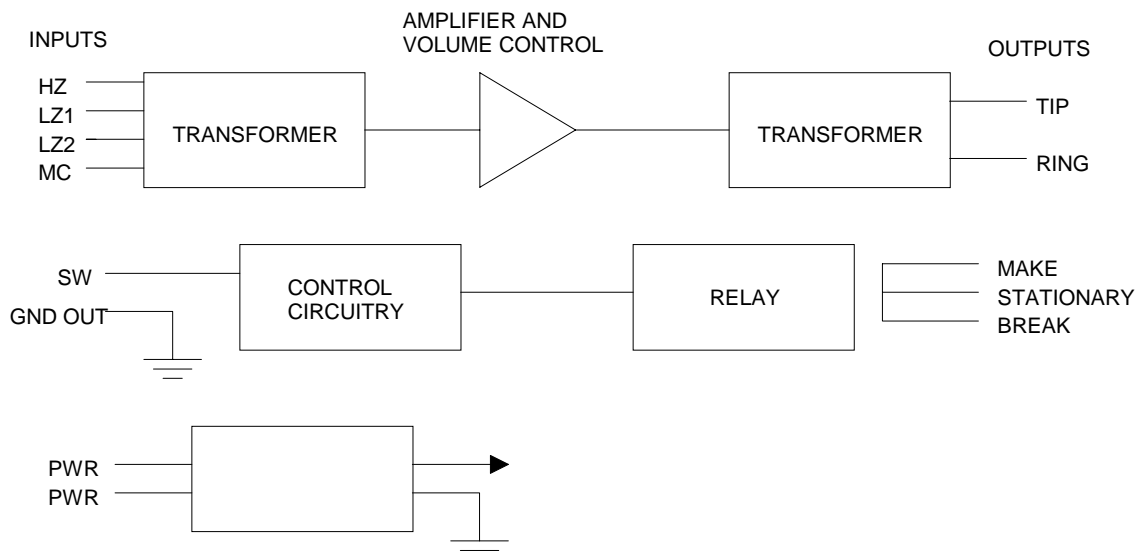

V-9939A SIMPLIFIED SCHEMATIC

VALCOM LIMITED WARRANTY

Valcom, Inc. warrants its products to be free from defects in materials and workmanship under conditions of normal use and service for a period of one year from the date of shipment. The obligation under this warranty shall be limited to the replacement, repair or refund of any such defective device within the warranty period, provided that:

1. inspection by Valcom, Inc. indicates the validity of the claim,
2. the defect is not the result of damage, misuse, or negligence after the original shipment.
3. the product has not been altered in any way or repaired by others and that factory sealed units are unopened (A service charge plus parts and labor will be applied to units defaced or physically damaged),
4. freight charges for the return of products to Valcom are prepaid,
5. all units 'out of warranty' are subject to a service charge. The service charge will cover minor repairs (Major repairs will be subject to additional charges for parts and labor).

This warranty is in lieu of and excludes all other warranties, expressed or implied, and in no event shall Valcom, Inc. be liable for any anticipated profits, consequential damages, loss of time or other losses incurred by the buyer in connection with the purchase, operation, or use of the product.

This warranty specifically excludes damage incurred in shipment. In the event a product is received in damaged condition, the carrier should be notified immediately. Claims for such damage should be filed with the carrier involved in accordance with the F.O.B. point.

Headquarters:
 Valcom, Inc.
 1111 Industry Avenue
 Roanoke, VA 24013
 Phone: (540) 427-3900
 FAX: (540) 427-3517

In Canada
 CMX Corporation
 35 Van Kirk Drive #11 and 12
 Brampton, Ontario L7A1A5
 Phone: (905) 456-1072
 FAX: (905) 456-2269