

V-9941A

ONE ZONE HANDSFREE TALKBACK CONTROL UNIT

INTRODUCTION

The V-9941A is a One Zone Handsfree Page Unit for use on an Electronic Key system line key position, a PABX loop start trunk port, a dedicated single line telephone or a 600 Ohm two-way page port with a contact closure.

These instructions contain the specifications and information necessary to install, operate and maintain the One Zone Handsfree Talkback Control Unit.

SPECIFICATIONS

Purpose

- Provides battery feed and loop detect circuitry to properly interface with a telephone system C. O. position or dedicated single line telephone.
- Provides VOX circuit and handsfree amplifier to drive 45 Ohm talkback speakers.
- Provides 600 Ohm input with ground start input to operate on E-Key systems with a 600 Ohm two-way page port and a contact closure.

Applications

- PABX loop start trunk port
- Electronic key system C. O. Line position
- Telephone systems with 600 Ohm two-way page port and contact closure
- Dedicated single line telephone

Refer to Figure 1 for a block diagram of a typical installation.

NOTE: When used with additional equipment, the V-9941A can also be accessed from a push-to-talk microphone for use in restaurant drive-in windows and other similar applications. Contact Valcom Application Engineering for information.



Features

- Loop start
- Input for ground start from a contact closure
- Provides optional battery feed
- Built in talkback amplifier
- Directly drives up to two talkback speakers
- Will drive Valcom one-way amplified speaker assemblies
- Screw terminals for all connections
- Initial alert tone option
- Repeated alert tone option
- Music input
- Speaker inhibit option
- Operates on -24VDC "B" Battery

Limitations

- Maximum of two Valcom talkback speakers plus 40 one-way amplified speaker assemblies.
- Maximum allowable cable distance from control unit to talkback speakers is 800 feet.

Capacity

- Each V-9941A will provide one zone of talkback paging
- The V-9941A is a single talk path unit
- Each V-9941A will drive up to two 45 Ohm talkback speakers
- Up to 40 one-way amplified speaker assemblies may be used in addition to the talkback speakers

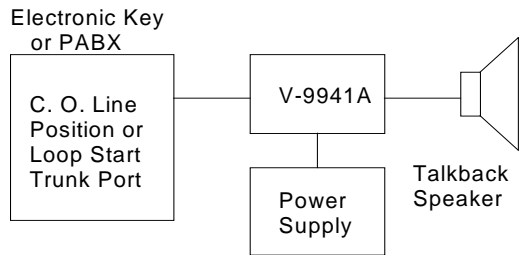

Figure 1 - Typical Loop Start Trunk Installation

Dimensions/Weight

- 8.25" H x 4.65" W x 2.30" D
(20.96cm H x 11.81cm W x 5.84cm D)
- 1.5 lbs. (0.68 kg)

Power Requirements

- 21.5 to -26VDC "B" Battery, 300mA maximum

Environment

Temperature: 0 to +50° C
Humidity: 0 to 85% (non-precipitating)

SYSTEM DESIGN

General

The Valcom V-9941A talkback control unit is designed to provide paging access from a C. O. position or loop start trunk port of a telephone system. The V-9941A may also be connected to a 600 Ohm two-way page port with a contact closure or a dedicated single line telephone. The V-9941A contains all the VOX and handsfree amplifier circuitry required to drive up to two Valcom 45 Ohm talkback speakers.

Electronic Key, PABX Access or Dedicated Single Line Telephone

The following components are required when paging from a PABX loop start trunk port, Electronic Key System C. O. line position or a Dedicated Single Line Telephone:

A telephone system C. O. line port or PABX loop start trunk port with a circuit card installed or a dedicated single line telephone:

- (1) V-9941A talkback control unit
- (1) VP-624B power supply
- 45 Ohm talkback speakers (maximum two)

Page Port Access (600 Ohms) with Contact Closure

The following components are required when paging from a 600 Ohm two-way paging port:

- 600 Ohm two-way paging port with contact closure
- (1) V-9941A talkback page control
- (1) VP-624B power supply
- 45 Ohm talkback speaker (maximum two)

Background Music

The V-9941A provides background music input and is designed to automatically cut off the music during a page. If background music is to be installed, a receiver providing an 8 Ohm output with 1-3 Watts of output power will be required.

Inhibit Option

The V-9941A is equipped with an inhibit lead that may be used in special applications to automatically turn off the speakers and allow a handset conversation between the calling party and a single line telephone connected to the paging Tip and Ring.

To use the inhibit function you will need a dedicated single line telephone modified for "A" Lead Control and a 5.1K Ohm 1/4 Watt resistor.

INSTALLATION

Mounting

Remove the metal mounting plate from the rear of the V-9941A enclosure. Using two #6 3/4 inch wood screws, mount the plate in a vacant space on the backboard with the telephone system common equipment. **Both mounting holes must be utilized to insure secure mounting of the unit.** See Figure 1A.

Open the V-9941A enclosure to access connections and option switches. Slide the rear of the unit (contains the board) onto the mounting plate and lock in place with screw provided. Make connections. Replace cover and lock in place with the #6 3/4 inch screw provided.

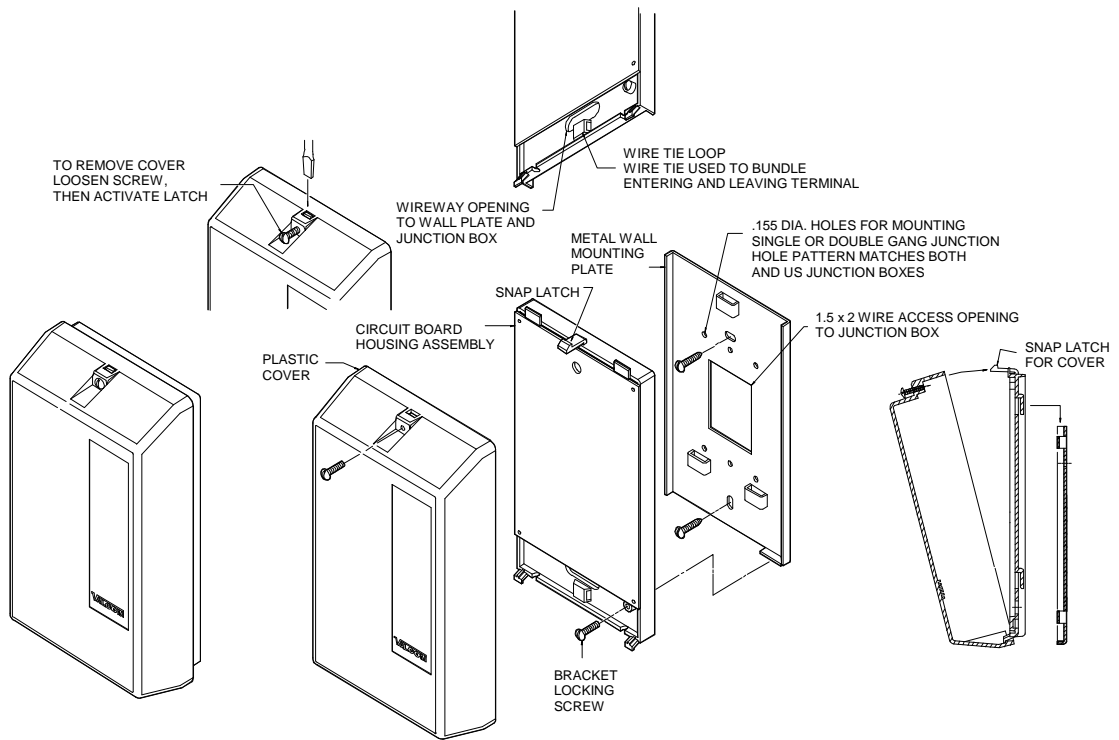
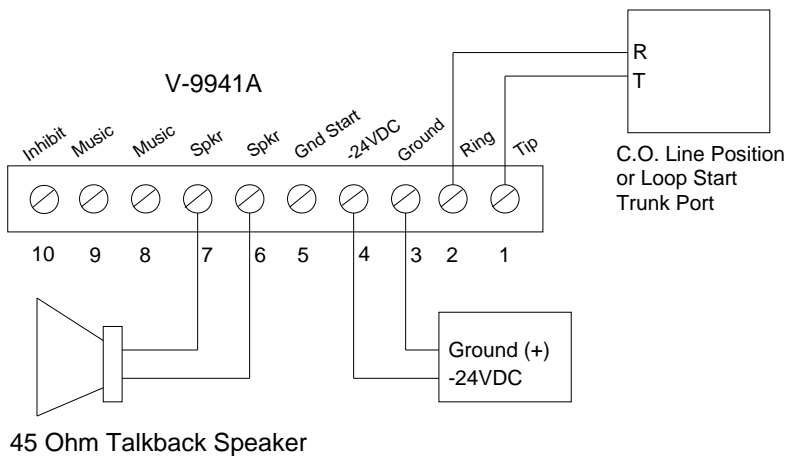

FIGURE 1A



ELECTRONIC KEY SYSTEM OR PABX ACCESS

INSTALLATION WIRING INSTRUCTIONS:

Place a check by each step as it is completed:

- ___ 1. Connect Tip of the telephone system trunk position to the V-9941A terminal 1 (TIP).
- ___ 2. Connect Ring of the trunk port to the V-9941A terminal 2 (RING).
- ___ 3. Connect Tip and Ring of the talkback speakers to the V-9941A terminals 6 and 7 (SPKR) of the V-9941A.
4. Option Switches:
 - ___ a. "SW1-1" controls the initial alert tone. Turn the switch ON to precede each page with an audible tone.
 - ___ b. "SW1-2" controls the repeated alert tone. Turn the switch ON to have a short tone burst every 15 seconds during a handsfree page.
 - ___ c. "SW3" turn ON (Battery Feed Switch).
- ___ 5. Plug in power supply.

NOTE: "A" battery may be substituted for "B" battery.
- ___ 6. Connect -24VDC "B" battery (may be referred to as "-" or "signal battery") from power supply to terminal 4 (-24VDC) on the V-9941A.
- ___ 7. Connect -24VDC "B" ground ("+" or "signal ground") from power supply to terminal 3 (GND).
- ___ 8. Connect -24VDC ground (+) from power supply to telephone system GROUND.

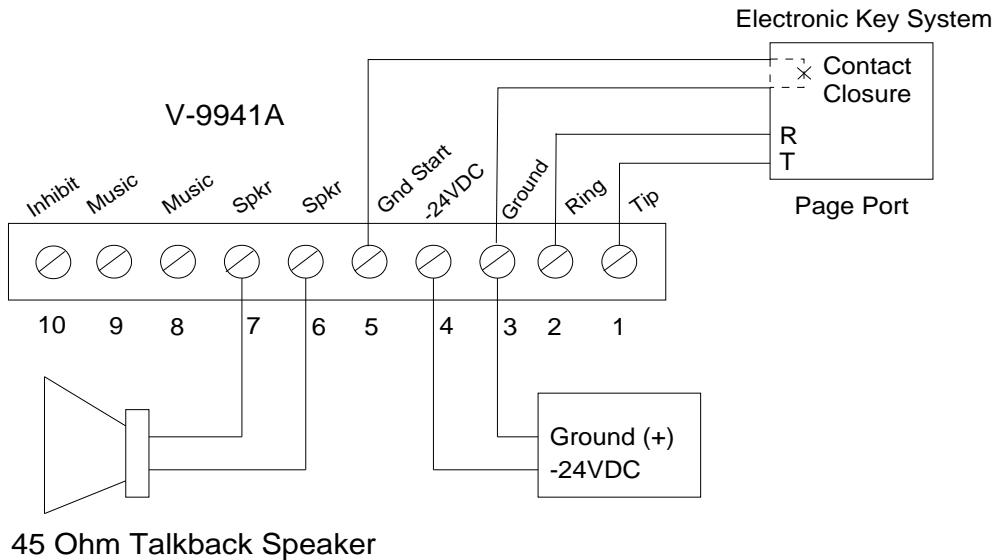

ELECTRONIC KEY PAGE PORT CONNECTIONS

WIRING INSTRUCTIONS:

- ___ 1. Connect Tip of the telephone system 600 Ohm page port to terminal 1 (TIP) of the V-9941A.
- ___ 2. Connect Ring of the 600 Ohm page port to terminal 2 (RING).
- ___ 3. Connect one side of the telephone system dry contact closure to terminal 3 (GND) of the V-9941A.
- ___ 4. Connect the other side of the contact closure to terminal 5 (GND ST) of the V-9941A.
- ___ 5. Connect Tip and Ring of the talkback speakers to the V-9941A terminals 6 and 7 (SPKR).
6. Option Switches:
 - ___ a. "SW1-1" controls the initial alert tone. Turn the switch ON to precede each page with an audible tone.
 - ___ b. "SW1-2" controls the repeated alert tone. Turn the switch ON to have a short tone burst every 15 seconds during a handsfree page.
- ___ 7. Plug in power supply.
NOTE: "A" battery may be substituted for "B" battery.
- ___ 8. Connect -24VDC "B" battery (may be referred to as "-" or "signal battery") from power supply to terminal 4 (-24VDC) on the V-9941A.
- ___ 9. Connect -24VDC "B" ground ("+" or "signal ground") from power supply to terminal 3 (GND).
- ___ 10. Connect -24VDC ground (+) from power supply to telephone system GROUND.
- ___ 11. " SW3 " turn to the OFF position (Battery Feed Off).

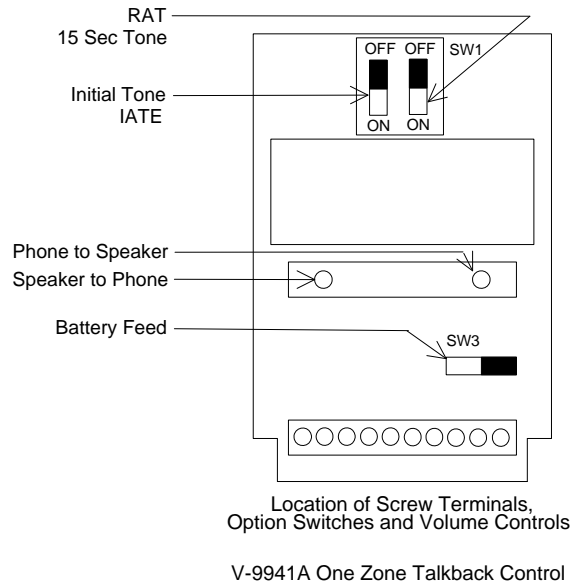

Volume Adjustments

There are two volume controls on the V-9941A. The control on the left adjusts the speaker to phone level and the control on the right adjusts the phone to speaker level. Turn the controls clockwise to increase the volume.

___ a. Speaker to Phone:

Adjust this control so the reply from the speaker is clear. **IMPORTANT:** This is the most critical adjustment. Set the volume at the lowest practical level. Setting this control too high will increase background noise without giving greater talkback volume.

___ b. Phone to Speaker:

Adjust this control to give the desired listening level at the speakers.

Optional Connections

A) **MUSIC:**

- ___ 1. Connect a pair from an amplified music source to terminals 8 and 9 (MUSIC) of the V-9941A.
- ___ 2. Adjust the control on the music source for the desired music level at the speakers.

B) **INHIBIT CONNECTIONS:**

- ___ 1. Verify the telephone being used has been modified for "A" Lead Control. Contact the telephone manufacturer for assistance if required.
- ___ 2. Connect Tip of the Telephone to terminal 1 of the V-9941A.
- ___ 3. Connect Ring of the Telephone to terminal 2.
- ___ 4. Connect the "A1" Lead of the Telephone to the V-9941A terminal 3.
- ___ 5. Connect the "A" Lead of the Telephone to one end of a 5.1K Ohm 1/4 Watt resistor.
- ___ 6. Connect the other end of the resistor to V-9941A terminal 10.

OPERATION

The V-9941A provides a -24VDC battery feed on Tip and Ring (SW3 ON). This provides "Talk Battery" to allow proper operation of PABX loop start trunk ports, Electronic Key system line key position or a dedicated single line telephone. A loop sense circuit connected with the battery feed turns on the V-9941A on access from the phone system. Note: By turning SW3 "OFF" and placing a ground on the ground start terminal, the unit may be accessed.

Immediately after access the V-9941A will send a tone to the speakers if the initial alert tone option has been enabled (SW1-1). The user will then be able to page to the speakers and receive a handsfree reply. As long as the person originating the call remains quiet, he will monitor the speaker. As soon as the caller begins to speak, the VOX circuit will switch and allow paging through the speaker. Throughout the call, if the 15 second repeated alert tone has been enabled (SW1-2) there will be a tone at the speaker every 15 seconds. When the calling party disconnects, the V-9941A will sense the open loop from the phone system and automatically turn off the speaker. If the V-9941A was accessed with a ground on the ground start lead, the unit releases when the ground is removed.

If the inhibit circuit has been connected to a single line phone and that phone goes off hook during a page, the V-9941A will sense approximately 5K Ohms to ground through the "A" lead contacts of the phone and it will turn off the speakers. Since the telephone Tip and Ring has been connected to the Valcom Tip and Ring, the called and calling parties may now converse.

An internal relay will automatically connect a music source (optional) to the speakers when the V-9941A is idle and remove the music during a page. During a page the music source will be connected to a 2.2 Ohm load resistor.

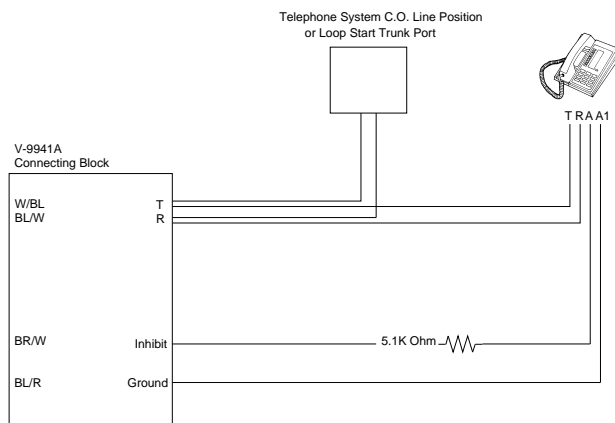

CONNECTIONS FOR INHIBIT OPTION

TECHNICAL ASSISTANCE

When trouble is reported, verify that power is being supplied to the unit and there are no broken connections. Check voltages for proper polarity on the cross connect block.

Table 1 identifies symptoms of some possible problems with solutions.

If a spare unit is available, continue to troubleshoot by substituting the spare unit for the suspected defective unit.

Assistance in troubleshooting is available from the factory. When calling, you should have a VOM, several clip leads and a test set available and be calling from the job site. Call (540) 563-2000 and press 1 for Technical Support, or visit our website at <http://www.valcom.com>.

Valcom equipment is not field repairable. Valcom, Inc. maintains service facilities in Roanoke, VA. Should repairs be necessary, attach a tag to the unit clearly stating your company name, address, phone number, contact person and the nature of the problem.

Send the unit to:

**Valcom, Inc.
Repair and Return Dept.
5614 Hollins Road
Roanoke, VA 24019-5056**

VALCOM LIMITED WARRANTY

Valcom, Inc. warrants its products only to the original purchaser, for its own use, to be free from defects in materials and workmanship under conditions of normal use and service for a period of one year from the date of shipment. This Limited Warranty obligation shall be limited to the replacement, repair or refund of any such defective device within the warranty period, provided that:

1. inspection by Valcom, Inc. indicates the validity of the claim;
2. the defect is not the result of damage, misuse or negligence after the original shipment;
3. the product has not been altered in any way or repaired by others and that factory sealed units are unopened (a service charge plus parts and labor will be applied to units defaced or physically damaged);
4. freight charges for the return of products to Valcom are prepaid;
5. all units 'out of warranty' are subject to a service charge. The service charge will cover minor repairs (major repairs will be subject to additional charges for parts and labor).

This Limited Warranty is in lieu of and excludes all other warranties, expressed or implied and in no event shall Valcom, Inc. be liable for any anticipated profits, consequential damages, loss of time or other losses incurred by the buyer in connection with the purchase, operation, maintenance, installation, removal or use of the product. The maximum liability of Valcom under this warranty is limited to the purchase price of the specific Product covered by the warranty.

Disclaimer. Except for the Limited Warranty provided herein, the product is provided "as-is" without any warranty of any kind whatsoever including, without limitation, any **WARRANTY OF MERCHANTABILITY, FITNESS FOR A PARTICULAR PURPOSE OR NON-INFRINGEMENT.**

This warranty specifically excludes damage incurred in shipment. In the event a product is received in damaged condition, the carrier should be notified immediately. Claims for such damage should be filed with the carrier involved in accordance with the F.O.B. point.

Headquarters:

Valcom, Inc.

5614 Hollins Road Roanoke, VA 24019-5056

Phone: (540) 563-2000 FAX: (540) 362-9800

TROUBLESHOOTING CHART	
Problem	Possible Solution
1. No talk battery on Tip and Ring 2. No paging at speaker	a. Verify good connections on terminals 1 (TIP), 2 (RING), 3 (GND), and 4 (-24VDC). Verify SW3 in "ON" position. a. Test system with two Lineman's Test sets: a. Disconnect TIP and RING of the V-9941A from the telephone system. b. Connect one test set across terminals 1 (TIP) and 2 (RING) of the V-9941A and the second test set across terminals 6 (SPKR) and 7 (SPKR). Turn SW3 "ON". c. While monitoring the second test set, go off hook on the first test set and page. d. If the page is heard when the V-9941A is working, verify the connections to the speakers. If your system still does not work, verify proper programming of your phone system. There should not be any type of toll restriction on the port used to access the Valcom equipment.
3. Paging at speaker but no reply from speaker	a. Verify talkback speakers are being used. (NOTE: Most page ports are not talkback compatible)

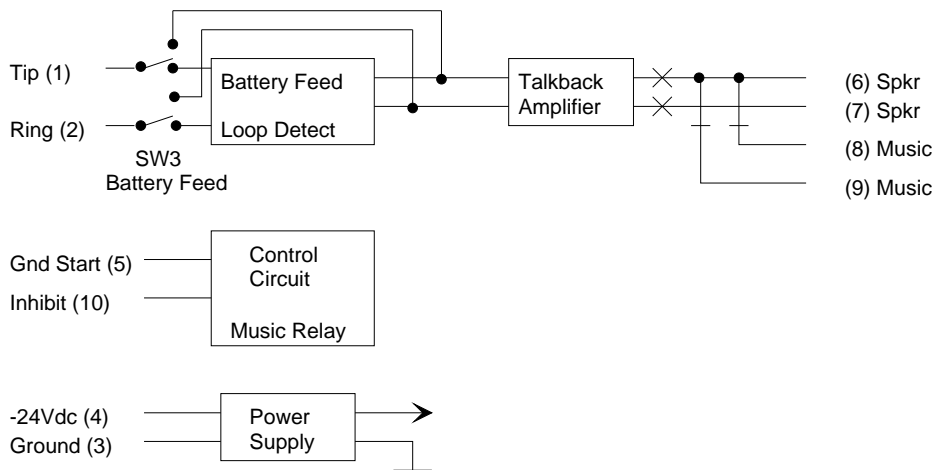

SIMPLIFIED SCHEMATIC

NOTE: Specifications are subject to change without notice.