

V-9983 2 CHANNEL MODULAR PRE-AMP/MIXER

V-9984 REMOTE INPUT MODULE

V-9985 4 CHANNEL MODULAR PRE-AMP/MIXER

INTRODUCTION

These instructions contain the specifications and guidelines necessary to install, operate, and maintain the Modular Pre-Amp/Mixer. The unit provides connections for up to 4 remote input modules. The mixer consists of a V-9983 Main Control Module and a V-9984 Remote Input Module.

The Modular Pre-Amp Mixer is used with Valcom distributed amplified one way paging systems providing additional audio source inputs.

The V-9985 provides active mixing for 1 balanced microphone and 2 auxiliary inputs. Also supplied is an additional audio input (building page) with an override feature. Up to 3 additional Remote Input Modules (V-9984) may be connected to the Main Control Module. Each Remote Input Module adds 1 Balanced Microphone and 1 Auxiliary input.

Applications

- Valcom, Inc. Distributed Amplified One-Way Paging Systems. Refer to Figure 1 for a block diagram of a typical installation.

Features

Main Control Module V-9983

- High impedance auxiliary input
- Volume control for auxiliary input
- 3.5mm stereo mini jack for auxiliary input
- Master volume control
- Up to (4) four remote mixer modules may be connected
- Separate outputs for Horns and Speakers
- Page port connection (Building Page) with override option switch
- Remote Volume Control Connection
- LED Signal Meter
- Built-in Compressor, option dip switch controlled



- Power "ON" indicator
- Mounts in 3 gang electrical box

MAIN CONTROL MODULE WITH REMOTE INPUT MODULE

Remote Input Module V-9984

- Balanced microphone
- XLR Mic. Connection
- Phantom power for electret microphones (Switch controlled)
- Phantom power "ON" indicator
- High impedance auxiliary input
- Volume control for auxiliary input
- 3.5mm stereo mini jack for auxiliary input
- Power "ON" indicator
- Mounts in single gang electrical box
- Connects to Main Control Module with 2 pair 24AWG station cable
- Screw terminals for distribution connections

Dimensions

Main Control Module

- 5"W x 4.25"H x 2"D
(12.7cm W x 10.8cm D x 5.08cm H)
- 0.4 lbs. (0.18 Kg)

Remote Input Module

- 1.64W x 4.25"H x 2"D
(4.17cm W x 10.8cm D x 5.08cm H)
- 0.25 lbs. (0.1Kg)

Specifications

Outputs

- Main Output: -10dBm nominal, 100 Ohms
- Frequency Response: 2Hz to 20kHz \pm 1dB
- Horn Output: -10dBm nominal, 100 Ohms
- Frequency Response 20Hz to 20kHz \pm 1dB (1dB/Octave High pass at 300Hz)

Tone Controls

- Bass (50Hz) boost or cut up to 12dB
- Treble (10kHz) boost or cut up to 12dB

Signal to Noise

- -80dB from maximum output

Auxiliary Input Sensitivity

- 10mVRMS for -10dBm output
- Input Impedance: >40 k Ω

Bldg Page Input Sensitivity

- 30mVRMS for -10dBm output
- Input Impedance: >4 k Ω (balanced input)

Signal Meter

- -10dBm output lights first 5 LED's
- 3dB per LED segment
- Compression Ratio: 2.5 fixed
- Attack: 1.5Ms
- Release: 0.3 seconds

Remote Volume Control

- 10 k Ω linear taper (gives audio taper)
- One pair connection

Power Requirements

- Voltage: 24VDC
- Current: 50mA

Remote Module

- Connections: 1 pair audio, 1 pair 24VDC (From main control module)
- Input Impedance: >4 k Ω (balanced)
- Maximum Input: 1Vrms

Microphone Input

- **Input Sensitivity:** 40uVRMS (-1 dBm out)
- Max Input: 30mVRMS
- **Input Impedance:** 3.5 k Ω Balanced

Signal to Noise

- -65dB from max output

Phantom Power

- 24VDC with 2.2 k Ω

Auxiliary Input

Sensitivity

- 10mVRMS for -10dBm output
- Max Input: 1.4VRMS
- Input Impedance: > 40 k Ω

Environment

- Temperature: 0 to 50°C
- Humidity: 0 to 85% non-precipitating

INSTALLATION

Figure 1 shows volume control locations, microphone and auxiliary input connections. Figure 2 shows output terminal strips and switches on the back of the mixer. Figure 3 shows a typical connecting arrangement. The V-9985 contains a Main Mixer Module and 1 Remote Module. Three additional remote modules may be connected to the main mixer module. Figure 4 shows other feature connections. Figure 5 shows Remote Input Module, Speaker and Power Connections.

All connections should be made to the mixer and double-checked prior to connecting DC power.

Connect the microphone to balanced XLR cables and the microphone XLR connector on the Remote Input Module. If the microphone is a condenser type it will require Phantom Power. Turn "ON" the Phantom Power Switch located on the Remote Module using a small scribe or paper clip. The Phantom Power LED will illuminate. The microphone volume control is located on the remote module. Other sources such as CD and MP3 players, tuners, and computer sound cards may be connected to the auxiliary inputs located on the remote and main modules. Volume controls for the auxiliary inputs are located on the remote input and main control module.

An additional audio input is available with a volume control located on the PC board for connection to a low level audio source such as a telephone page port or Valcom One-Way Page Control. An option dip switch located on the PC board enables the input to override the microphone and auxiliary inputs.

A compressor is available to even out a user's voice to compensate for poor microphone or vocal technique and allow more microphone gain before feedback. All auxiliary and microphone inputs are routed through the compressor when enabled. An option dip switch located on the PC board enables the compressor.

A connection is provided to add a remote volume control. This is a 2 wire connection using a 10K Ohm linear potentiometer.

Speaker Connections

Connect Tip and Ring of Valcom Amplified Speakers to the output screw terminals located on the Main Mixer Module. Connect Tip and Ring of Valcom Amplified Paging Horns to horn audio output screw terminals.

When setting the system up, it is recommended that the master gain control be set 2/3 and aux volume controls be set to 1/4.

SETUP

Without a source connected set all V-9984/9985 aux volume controls full "counter clockwise". Turn "BLDG Page" full counter clockwise. Set V-9983 Master Volume between 2/3 and 3/4 clockwise from "OFF" position. Turn on aux or Microphone source. Watching the LED VU, adjust the Aux or Microphone volume until the "(0)" dB light is flashing occasionally. If "0" dB cannot be achieved turn up source level.

When using "Building Page Input" adjust BLDG Page volume until the "(0)" light is flashing occasionally during page. After adjustments are made, set speaker volumes to appropriate levels.

If the input volume levels require additional adjustment, use the aux volume controls on the remotes not the master volume control. Under no circumstances should the V-9983 "Master Volume Control" be adjusted below 2/3.

OPERATION

The V-9985, Four Channel Pre-Amp/Mixer actively mixes any signals present on the inputs. Each input is equipped with its own volume control to allow blending of the input sources. The unit also has a master volume control to allow a volume level adjustment of all mixed signals. Bass and treble controls allow up to 12dB of boost or cut at 50Hz and 10kHz.

An audio input is available on the main control module allowing connection of a low level signal that will override all other inputs. An option dip switch controls the override feature.

The integrated compressor feature is controlled by an option dip switch. Microphone and auxiliary inputs are routed through the compressor when the compressor is active.

Two outputs are provided by the V-9985 modular mixer.

- An output to drive full range speakers
- An output to drive limited range paging horns

TECHNICAL ASSISTANCE

When trouble is reported, verify there are no broken connections. Assistance in troubleshooting is available from the factory. Call (540) 563-2000 and press 1 for Technical Support, or visit our website at <http://www.valcom.com>.

Valcom equipment is not field repairable. Valcom, Inc. maintains service facilities in Roanoke, VA. Should repairs be necessary, attach a tag to the unit clearly stating company name, address, phone number, contact person and nature of the problem. Send the unit to:

**Valcom, Inc.
Repair & Return Dept.
5614 Hollins Road
Roanoke, VA 24019-5056**

VALCOM LIMITED WARRANTY

Valcom, Inc. warrants its products only to the original purchaser, for its own use, to be free from defects in materials and workmanship under conditions of normal use and service for a period of one year from the date of shipment. This Limited Warranty obligation shall be limited to the replacement, repair or refund of any such defective device within the warranty period, provided that:

1. inspection by Valcom, Inc. indicates the validity of the claim;
2. the defect is not the result of damage, misuse or negligence after the original shipment;
3. the product has not been altered in any way or repaired by others and that factory sealed units are unopened (a service charge plus parts and labor will be applied to units defaced or physically damaged);
4. freight charges for the return of products to Valcom are prepaid;
5. all units 'out of warranty' are subject to a service charge. The service charge will cover minor repairs (major repairs will be subject to additional charges for parts and labor).

This Limited Warranty is in lieu of and excludes all other warranties, expressed or implied and in no event shall Valcom, Inc. be liable for any anticipated profits, consequential damages, loss of time or other losses incurred by the buyer in connection with the purchase, operation, maintenance, installation, removal or use of the product. The maximum liability of Valcom under this warranty is limited to the purchase price of the specific Product covered by the warranty.

Disclaimer. Except for the Limited Warranty provided herein, the product is provided "as-is" without any warranty of any kind whatsoever including, without limitation, any **WARRANTY OF MERCHANTABILITY, FITNESS FOR A PARTICULAR PURPOSE OR NON-INFRINGEMENT.**

This warranty specifically excludes damage incurred in shipment. In the event a product is received in damaged condition, the carrier should be notified immediately. Claims for such damage should be filed with the carrier involved in accordance with the F.O.B. point.

Headquarters:

Valcom, Inc.

5614 Hollins Road Roanoke, VA 24019-5056

Phone: (540) 563-2000 FAX: (540) 362-9800

REMOTE INPUT MODULE

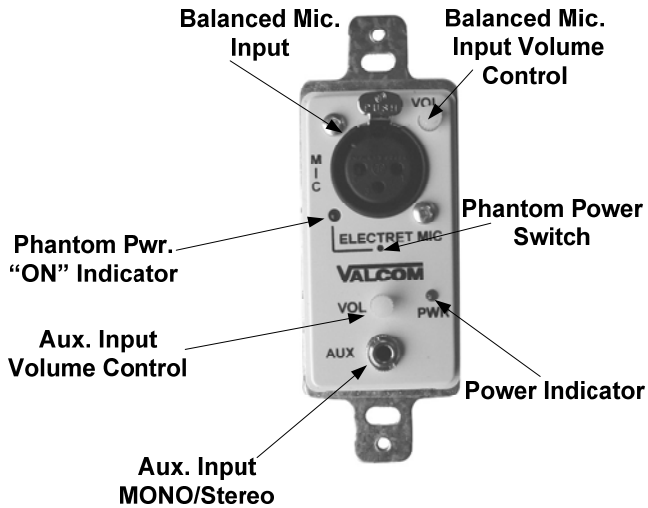

MAIN CONTROL MODULE

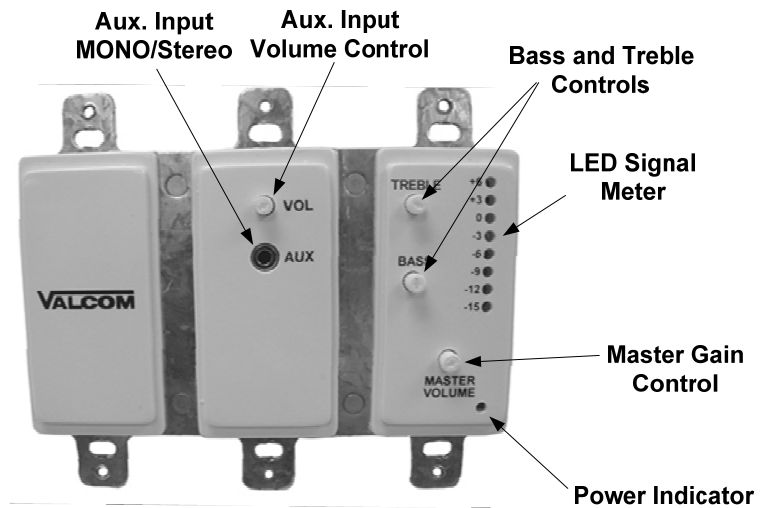

Figure 1: Main and Remote Mixer Front Layout

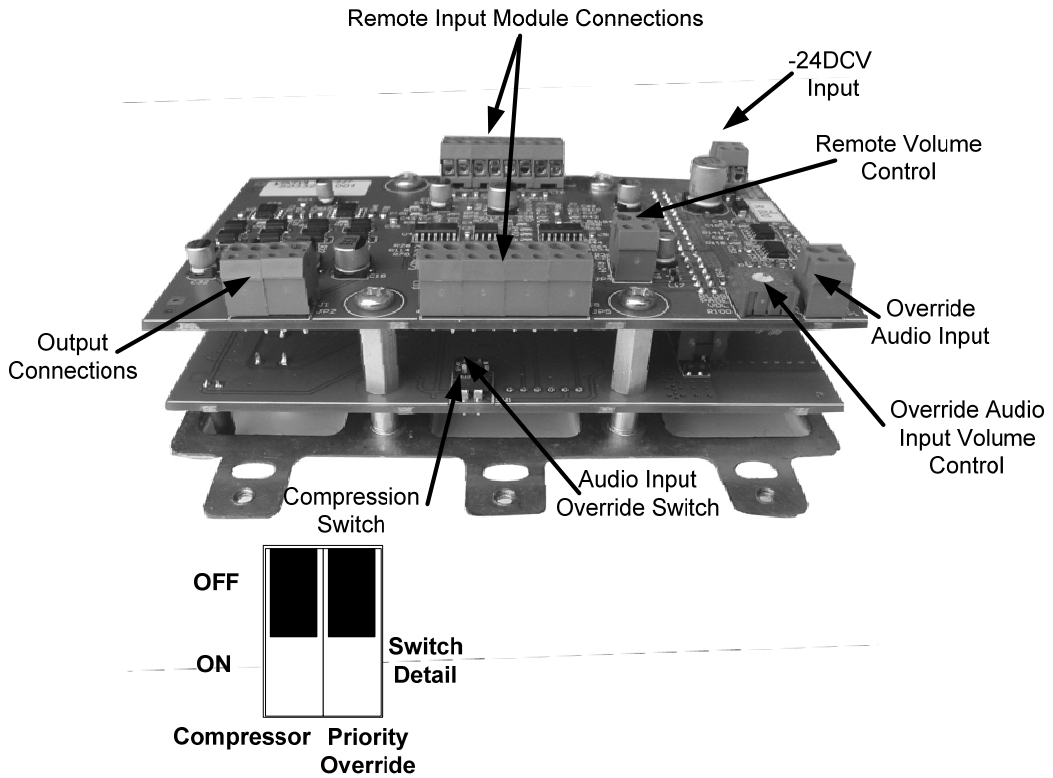

Figure 2: Rear Main Control Module

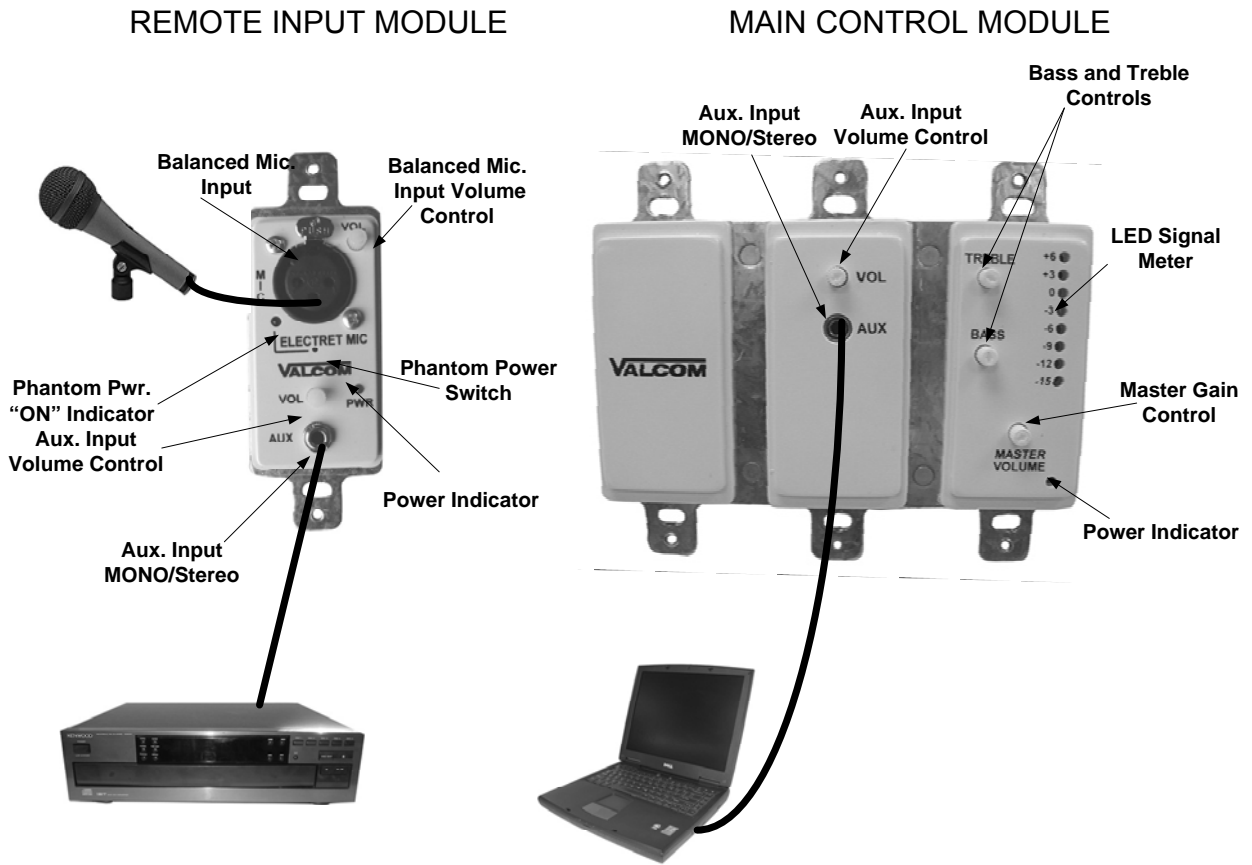

Figure 3: Typical Connections

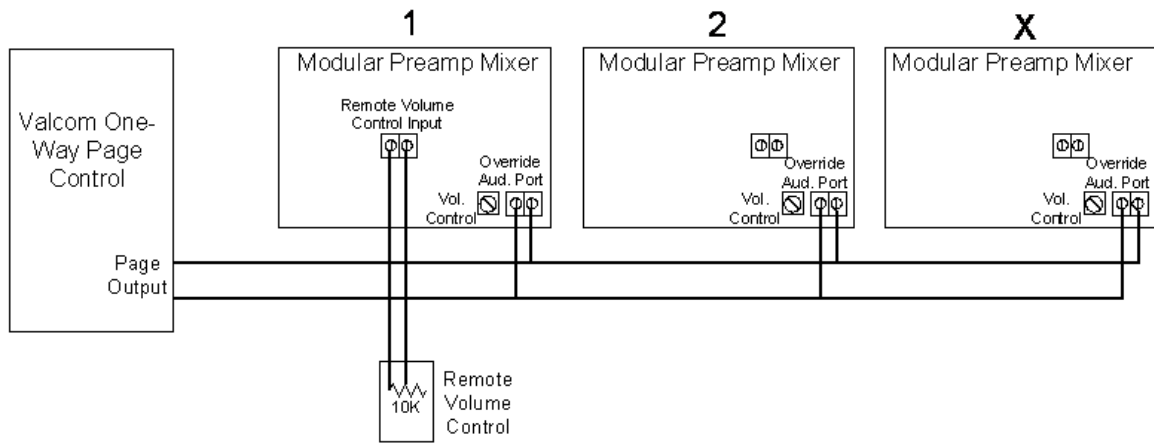

Figure 4: Other Feature Connections

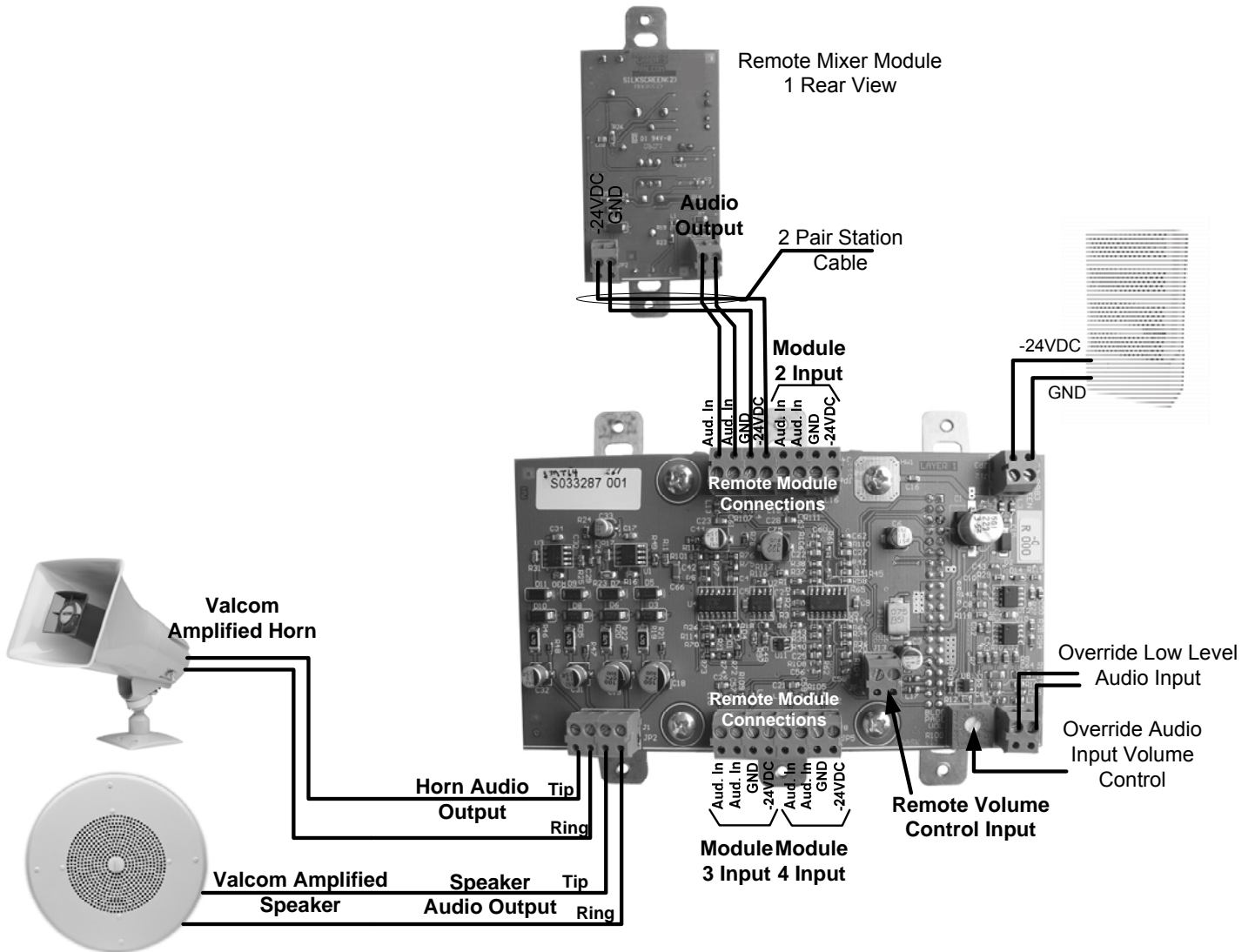

Figure 5: Input, Power and Speaker Connection