



Installation Manual V10.5

Valcom Wired Digital Clock

V-D11025B, V-D11040B, V-D2425B, V-D2440B, V-2425B-6,
and V-D2440B-6



Valcom Digital Series 2-Wire and 3-Wire Clocks

Table of Contents

Table of Contents	2
Important Safety Instructions	3
Wall Mount Installation	4 - 10
Flag Mount Installation	11 - 19
Double Mount Installation	20 - 28
Adjustable Jumper Settings	29
Inputs	
System Side - 2-Wire Digital Communication	30
- 3-Wire Synchronous (Sync-Wire)	
Communication 110VAC	31 ■
Clock Side - Sync-Wire	32-35 ■
Outputs	36 ■
Manual Controls	37-43 ■
Reading the Display	44
Frequently Asked Questions	45
Troubleshooting	46
Warranty	47

■ Available with V-D110XXB models only

Important Safety Instructions

VERY IMPORTANT:

KNOW YOUR COMMUNICATION PROTOCOL

The Valcom V-D110XXB Digital clocks are designed to support various 3-wire (sync-wire) communication protocols. To run each protocol properly, the clock requires the correct wiring format. It is very important that you only follow the wiring instructions appropriate to your clock's communication protocol. Using the wrong wiring format may damage the clock.

DANGER

SHOCK HAZARD

- Keep the electricity to this device turned OFF until the clock installation is complete.
- Do not expose the clock movement to water, or install the clock in a location where it may be exposed to water.

NOTICE

- Do not install the clock outdoors. Damage to the clock if placed outdoors voids the warranty.
- Do not hang objects from the clock or clock mounting parts. The clocks are not designed to support the weight of other objects.
- The clock face and housing may be cleaned with a damp cloth or disinfectant. Test other cleaning products on a small part of the clock housing before attempting to use on the rest of the clock. Avoid bleach and chemicals known to dissolve plastics.

WARNING

FIRE HAZARD



- Always follow your national and regional electrical codes or ordinances.
- The AC power circuit for the clock must be attached to a circuit breaker that can be reset by the user.

PHYSICAL INJURY HAZARD

- If you are standing on an object while installing your clock, make sure that the object can support your weight, and will not sway or move as you stand on it.
- Take precautions to avoid injury by potential safety hazards near the point of installation including (but not limited to) heavy machinery, sharp objects, hot surfaces, or exposed cables carrying an electric current.
- Follow all mounting instructions exactly as stated in this manual. Failure to do so may result in the device falling off the point of installation.
- Packaging materials and mounting items include plastic bags and small pieces, which pose a suffocation hazard to young children.

Wall Mount Installation

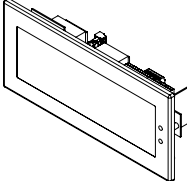
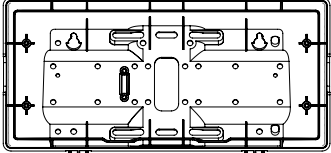
Included in Package

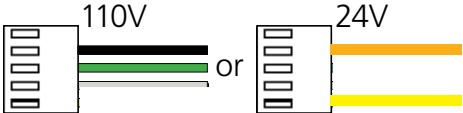
Description	Quantity	Picture
Valcom Digital Clock	1	
Digital Clock Wall Housing	1	
6-19x1/2 screw	4	
6-32x1 screw	4	
Included in Wiring Kit (D-PK-3-110-S or D-PK-3-24-S)		
Power/grounding wires and connector	1	

PLEASE NOTE: A user will also have to provide a Phillips-head screwdriver, a small flat-blade screwdriver, a single gang box, any equipment needed to install the gang box, and any additional wiring needed to extend the signal, power, or ground cables. You may also need a 1/4 inch drill, 4 #8x1.5 self-tapping screws, and 4 wall anchors for those screws if you decide not to attach the clock directly to the gang box.

If any of the items listed in the wiring kit are missing, you may contact Valcom and order a replacement kit.

Wall Mount Installation

1) If you are installing a new gang box in the wall, leave at least 4 inches between the top of the gang box and ceiling. Confirm that the bottom of the gang box is level with the floor.

If you are using an existing gang box, the top of the gang box must be a minimum of three inches away from the ceiling.

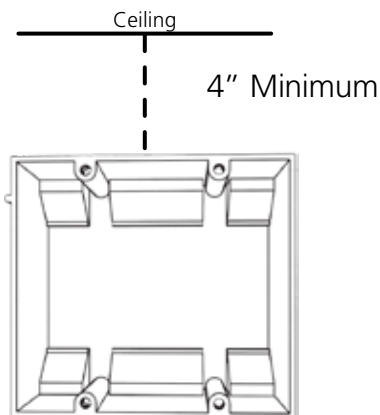

3) Attach the communication and power wires from your kit to the communication and power wires in the gang box. See the sections of this manual labeled "Communication Wiring Information" for additional details, depending on your system.

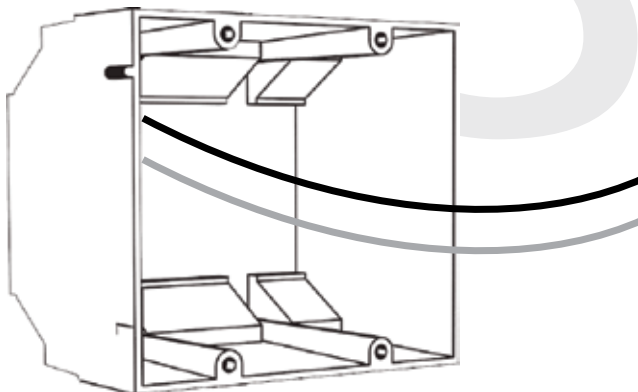

2) Run power and communication wiring to the gang box. See the sections of this manual labeled "Inputs - System Side" for additional details, depending on your system.

CHECK YOUR WIRING

The voltage between the white and black wires should measure 105-126 volts AC in the 110 volt model, or Yellow & orange wires for 21.5-26.5 volts DC in the 24 volt model.

If you are using the 24 volt model, make sure that the wiring leading to the clock is from a Valcom power supply or V-VCU.

4) If you do not wish to attach the housing to the gang box, proceed to step 5A. Otherwise, go to step 6.

Wall Mount Installation

5A) If you do not wish to attach the housing to a gang box, place the mounting piece on the wall. Leave at least 4 inches between the top rear edge of the housing and ceiling. Confirm that the bottom of the mounting piece is level with the floor.

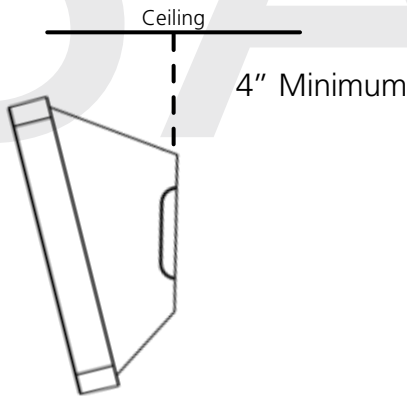

5B) Identify the keyholes towards the top of the back of the clock housing. Use a pencil to trace the top of each keyhole onto the wall, then use the 1/4 inch drill bit to drill holes at the locations of the two marks.

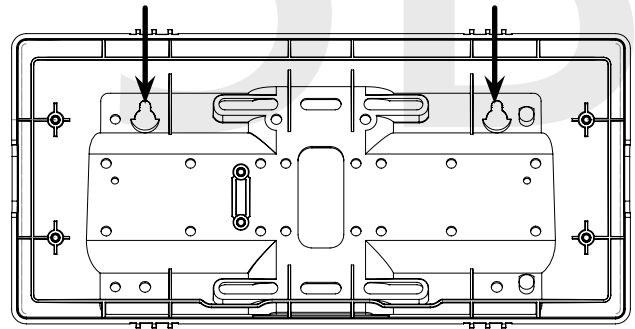

5C) Insert the wall anchors into the two holes, then place a #8 self-tapping screw into each wall anchor, leaving at least a 1/8" gap between the top of the screw and the wall.

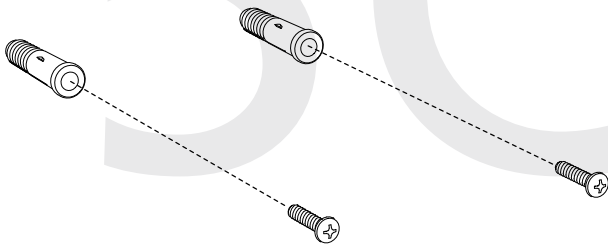

5D) Use the keyholes in the back of the housing to hang the clock onto the screws.

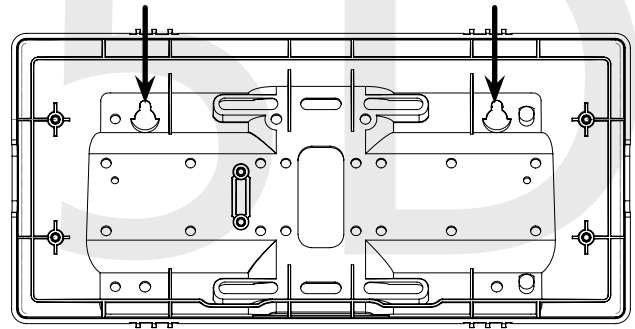

Wall Mount Installation

5E) Use a pencil to trace the holes beneath each keyhole onto the wall. Take the clock housing off the wall, drill holes at the marked locations, and add another two wall anchors.

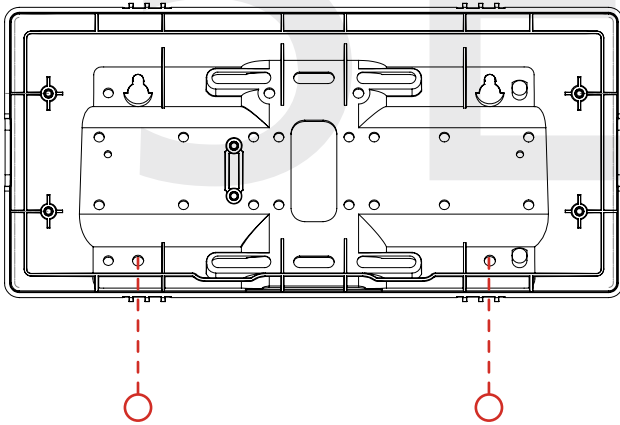

5F) Repeat step 5D, then pass another pair of #8 screws through the bottom holes and secure them in the remaining two wall anchors.

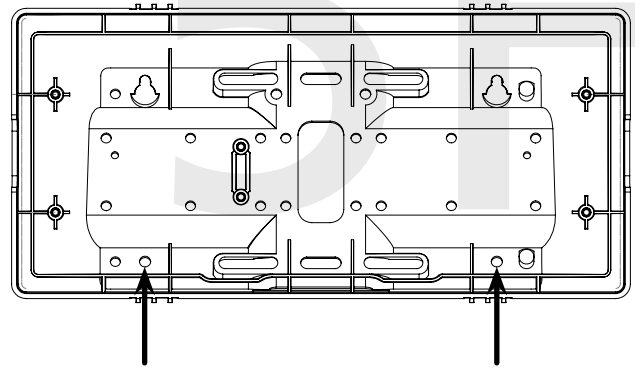

5G) Run power and signal wires through the large hole in the back of the housing. Secure the wires by passing them through the wire clamp.

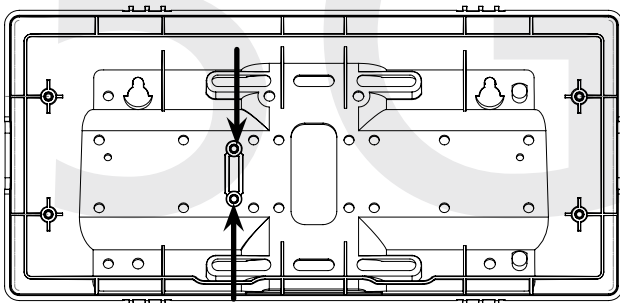

6) Perform step 5F, then attach the housing to the gang box using the #6-32x1 screws.

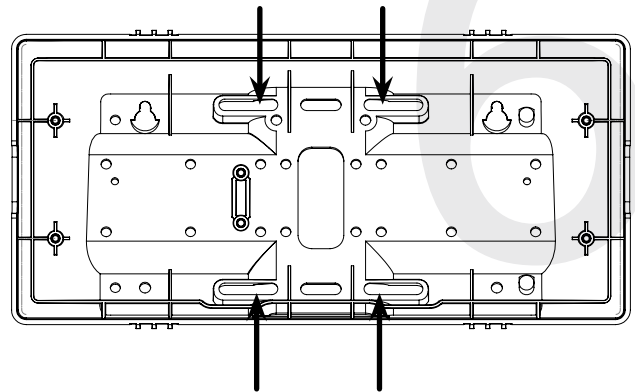

Wall Mount Installation

7) Detach the filter from the clock display board by pressing inward on the red tabs.

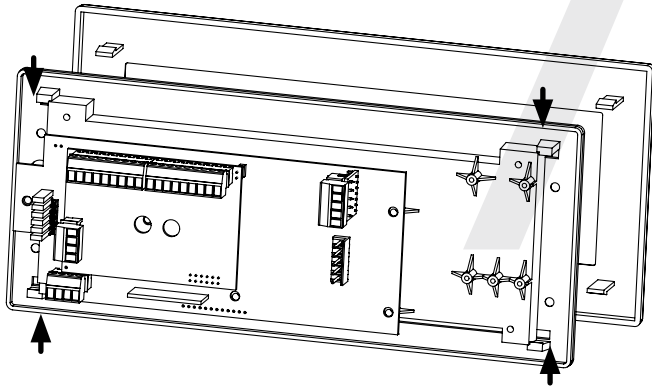

8A) If you are installing a digital clock that uses a 2-wire digital sync system, attach the wires to the port as shown below.

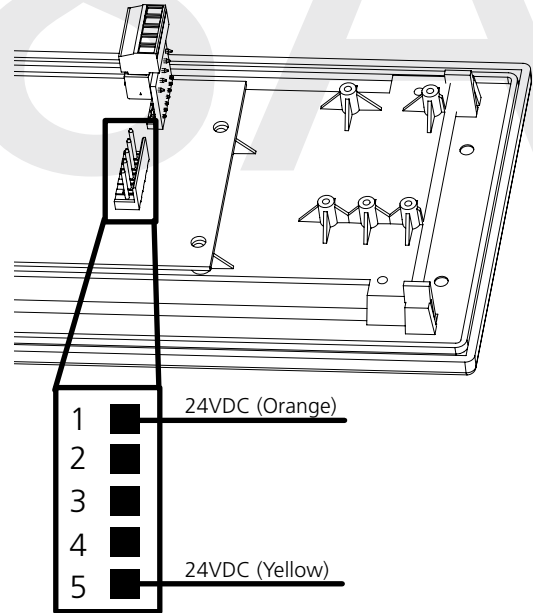

8B) If you are installing a digital clock that uses sync-wire correction, attach the wires to the appropriate sync-wire ports. Refer to the section, "Inputs - Clock Side - Sync Wire" for instructions regarding each system.

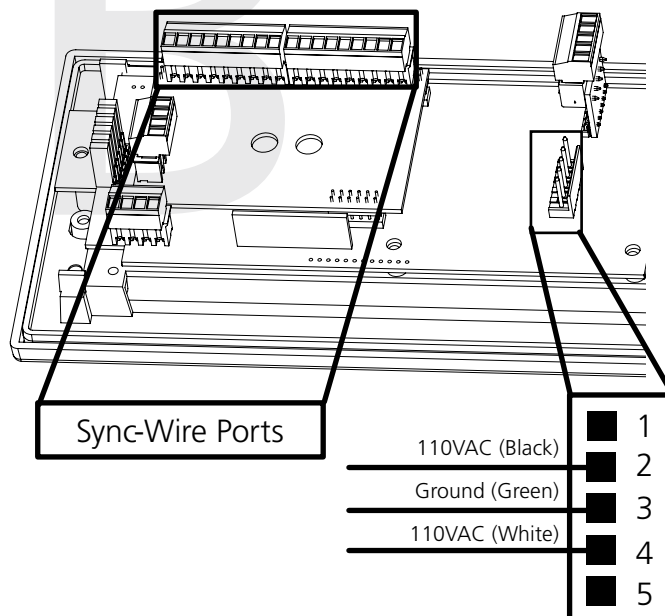

Wall Mount Installation

9) Detach the frame from the front of the clock housing by pulling the bottom and top edges away from the housing.

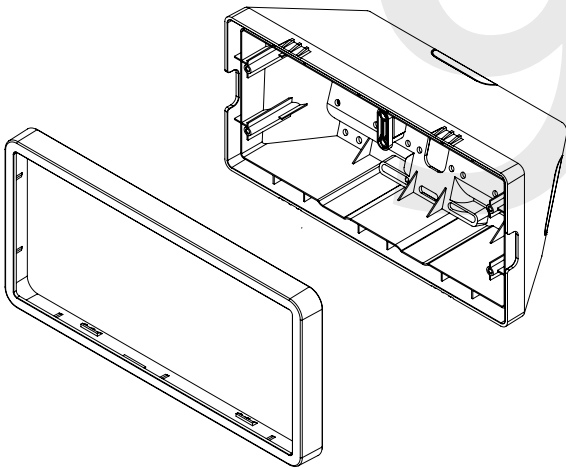

10) Use the 6-19x1/2 screws to attach the display board to the housing.

NOTE: For 2.5" Digit clocks, the holes for the screws will be on the left and right inner surfaces of the housing. For 4.0" Digit Clocks, the holes will be on the top and bottom surfaces.

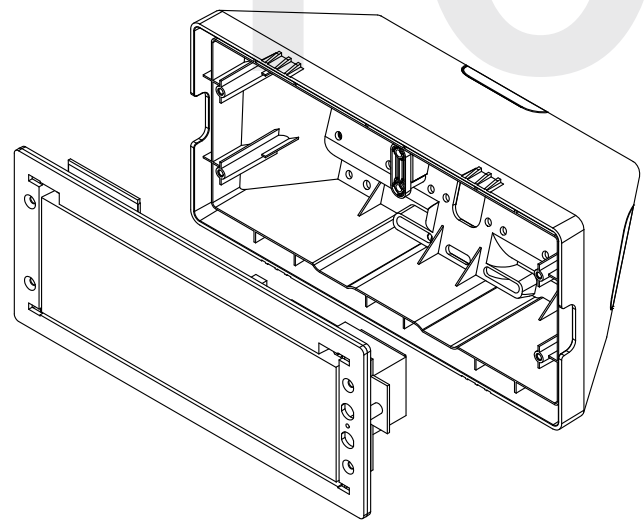

11) Remove the plastic cover from the display board.

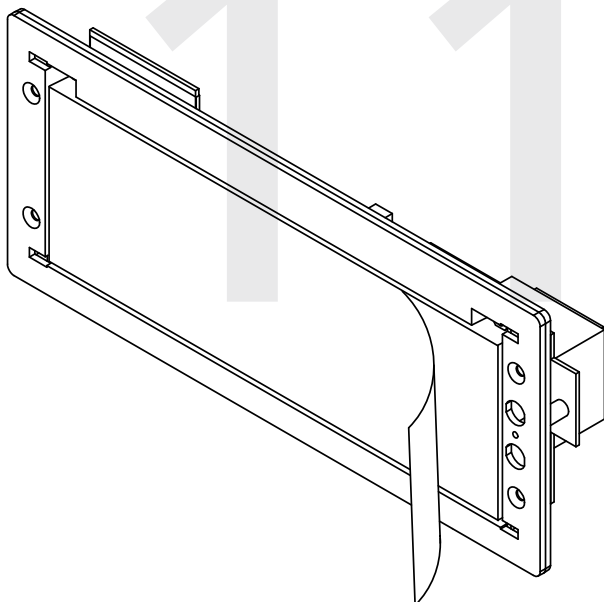

12) Place the filter over the display board. You should hear a snapping noise as the latches drop into place.

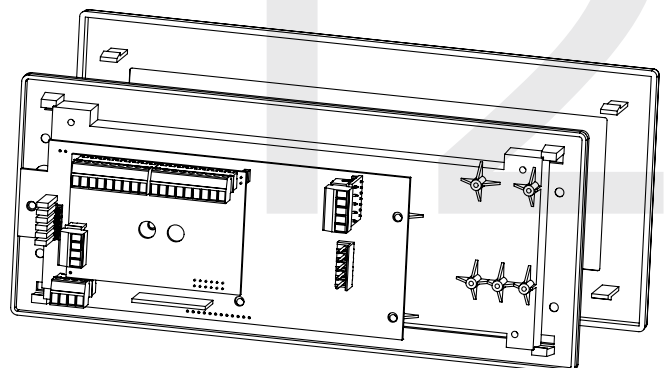

Wall Mount Installation



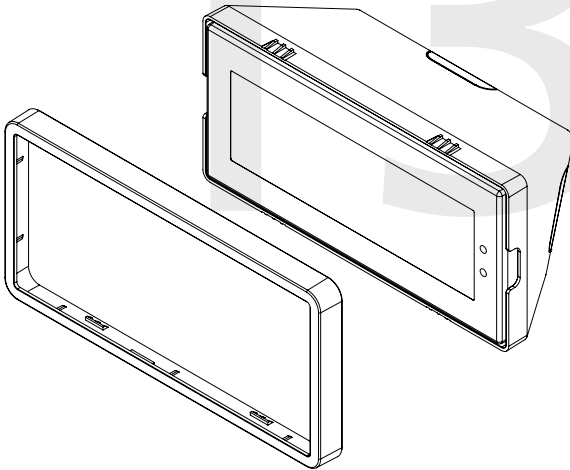



13) Place the housing frame onto the housing. You should hear a snapping noise as the latches drop into place.

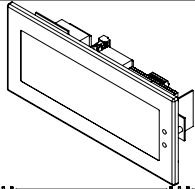
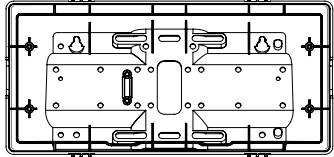
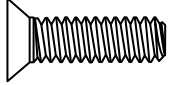

14) Power the clock. After testing the LED segments and presenting some diagnostic information, the clock will display the time based off of its internal quartz oscillator. It will correct itself to show synchronized time as soon as it receives data from a master clock.

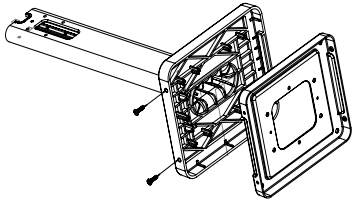
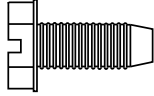
Flag Mount Installation

Included in Package

Description	Quantity	Picture
Valcom Digital Clock	1	
Digital Clock Wall Housing	1	
6-19x1/2 screw	4	
6-32x1 screw	4	
Included in Pole Kit (V-DMKIT)		
Dual-mount pole, including mounting plate	1	
#10-32x3/8 green screw	1	
#8-32x7/16 screw	8	
M3.5-1.0x10 screw (black)	4	
Internal-tooth washer	8	

Continued on next page

If any of the items listed in the kits are missing, you may contact Valcom and order a replacement kit.

Flag Mount Installation

#6-32x1 screw

4



Adapter tab screws

4



Included in Wiring Kit (D-PK-3-110-S or D-PK-3-24-S) - 2 kits included

Power/grounding wires
and connector

1

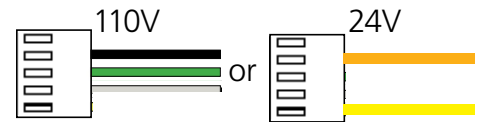

PLEASE NOTE: A user will also have to provide a Phillips-head screwdriver, a small flat-blade screwdriver, a single gang box, any equipment needed to install the gang box, and any additional wiring needed to extend the signal, power, or ground cables. You may also need a 1/4 inch drill, 4 #8x1.5 self-tapping screws, and 4 wall anchors for those screws if you decide not to attach the clock directly to the gang box.

If any of the items listed in the wiring kit are missing, you may contact Valcom and order a replacement kit.

Flag Mount Installation

1) Install the double gang box in the wall or ceiling. If you are installing the gang box in the wall, leave at least eleven inches between the top of the gang box and the ceiling. If you are installing the gang box in the ceiling, leave at least eleven inches between the gang box and the wall. The box should be installed level and plumb with the wall and ceiling.

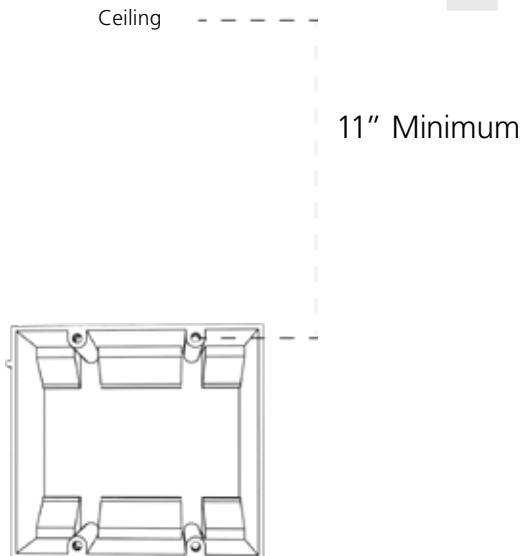

3) Detach the mounting plate from the mounting pole by unscrewing the two screws. Set the screws and pole aside for later.

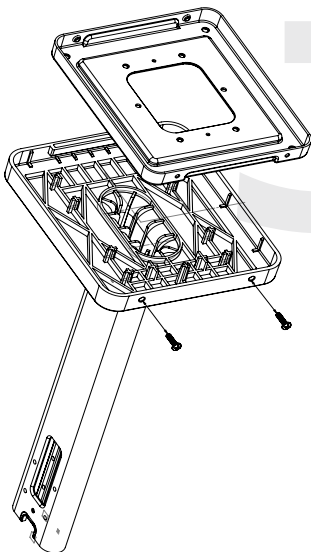

2) Run power and communication wiring to the gang box. See the sections of this manual labeled "Inputs - System Side" for additional details, depending on your system.

CHECK YOUR WIRING

The voltage between the white and black wires should measure 105-126 volts AC in the 110 volt model, or Yellow & orange wires for 21.5-26.5 volts DC in the 24 volt model.

If you are using the 24 volt model, make sure that the wiring leading to the clock is from a Valcom power supply or V-VCU.

4) Attach the mounting plate to the gang box using only two of the four long, silver #6-32x1 screws. With the mounting plate as a guide, use the pencil to trace the locations of the four larger holes at the outer corners.

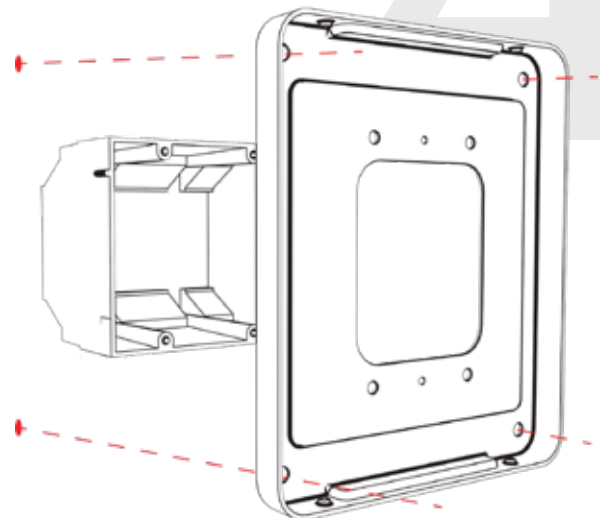

Flag Mount Installation

Steps 5 and 6 only apply to metal mounting poles. If you have an ABS mounting pole, skip to step 7

5) Remove the mounting pole end cap and the plastic ring from one of the holes.

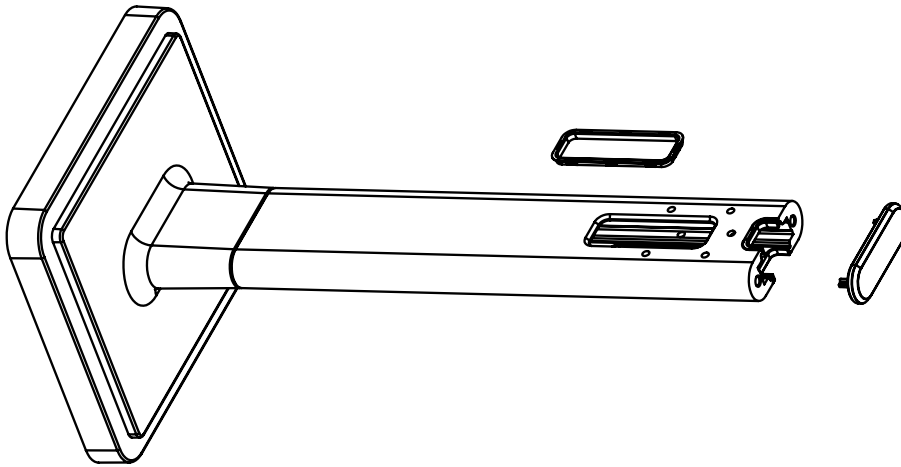

6) Attach the flag-mount end cap to the pole. Confirm that the covering flap is attached to the side where the plastic ring was removed.

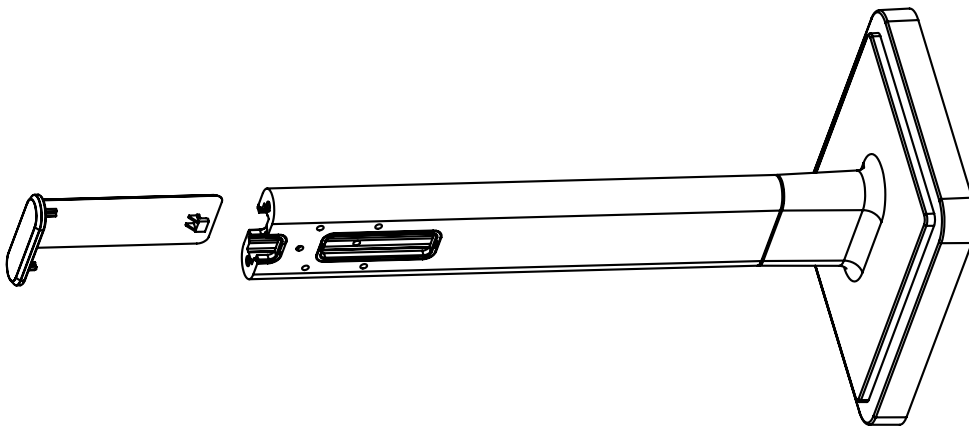

Flag Mount Installation

7) Remove the mounting plate and drill the four holes that were just traced. Insert the four wall anchors into the holes.

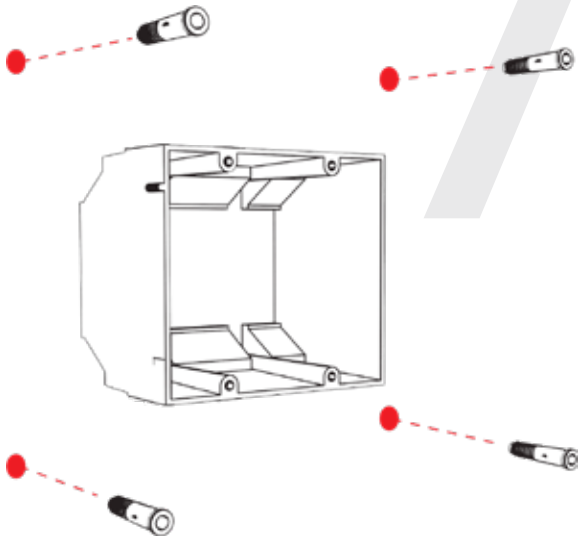

8) Reattach the mounting plate, this time using all four long, silver #6-32x1 screws, then insert the four #8 screws through the mounting plate and into the anchors.

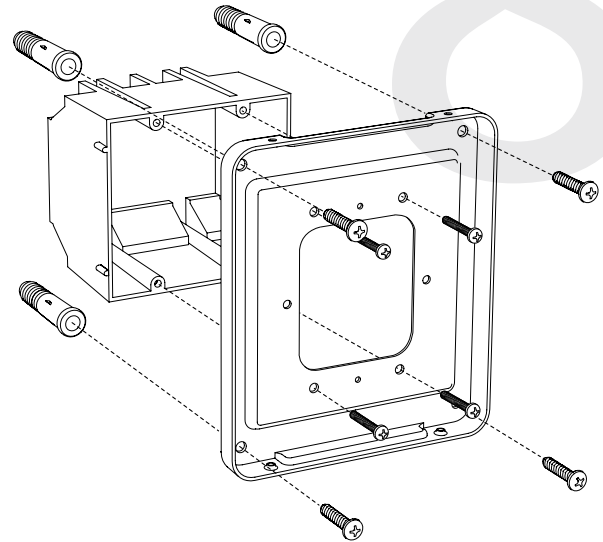

9) Thread any wiring through the mounting plate, and attach a grounding wire to the mounting plate using one of the larger centered holes and the #10-32x3/8 screw.

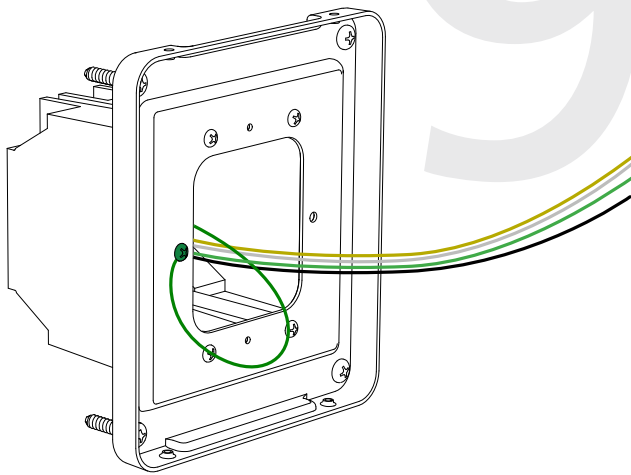

10) Use a screwdriver to remove one of the end caps. The selected end cap should match the position of the orientation of the clock on the mounting pole; for example, if you wish to attach the clock to the pole in a ceiling-mount configuration, then the top end cap should be removed. The end cap and screw that was used to secure it will not be needed again during this installation.

Flag Mount Installation

11) Detach the frame from the front of the clock housing by pulling the bottom and top edges away from the housing.

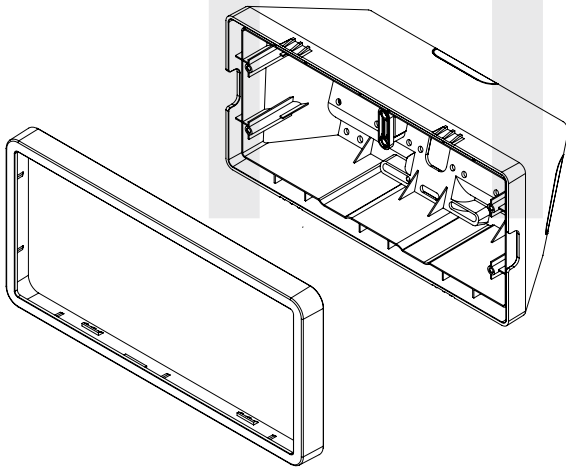

12) Insert the four #8-32x7/16 screws through the internal-tooth washers, then through the adapter, and finally into the pole. Use a screwdriver to tighten the screws so that the adapter does not move.

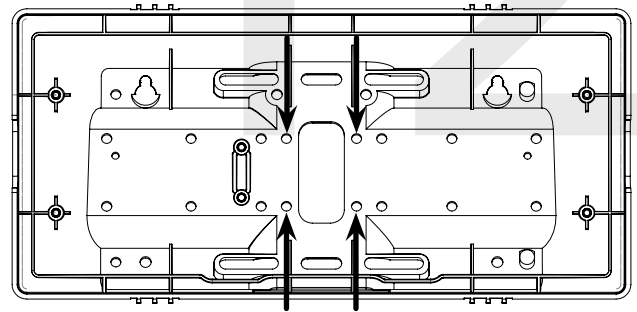

13) Thread at least fifteen inches (38.1cm) of wiring from the gang box through the bottom of the pole until each wire exits through the hole in the adapter.

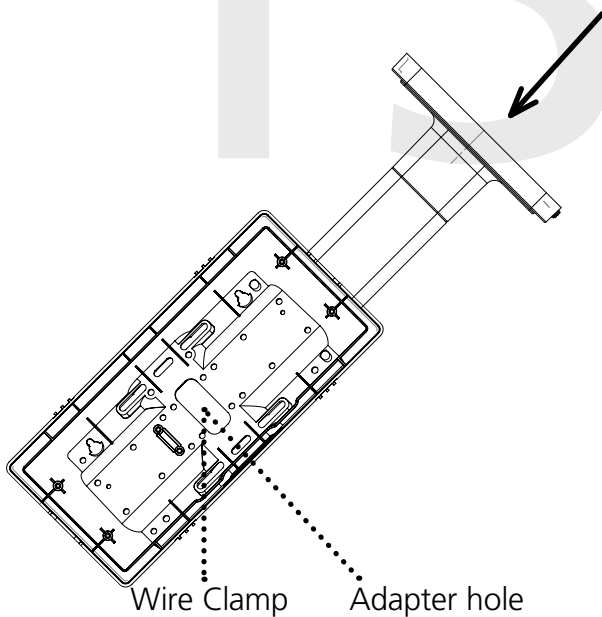

14) Detach the filter from the clock display board by pressing inward on the red tabs.

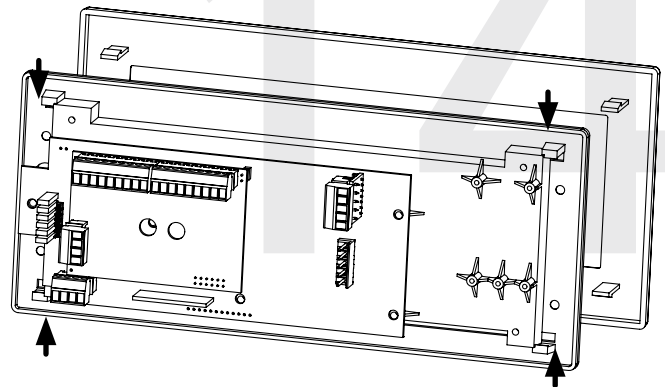

Flag Mount Installation

15A) If you are installing a digital clock that uses a 2-wire digital sync system, attach the wires to the port as shown below.

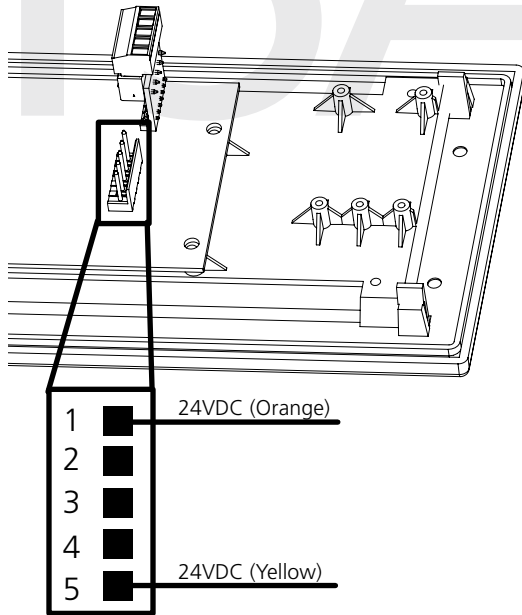

15C) If you are installing a digital clock that uses sync-wire correction, attach the wires to the appropriate sync-wire ports. Refer to the section, "Inputs - Clock Side - Sync Wire" for instructions regarding each system.

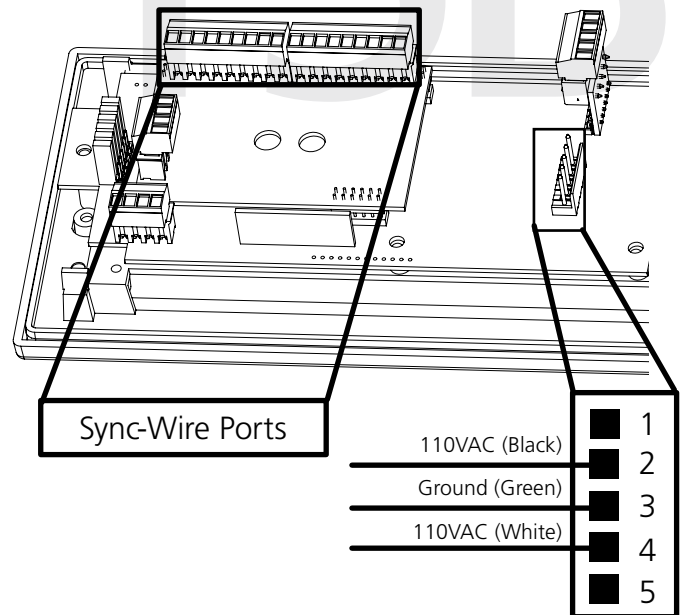

16) Use the M3/5-15x12 screws to attach the display board to the housing.

NOTE: For 2.5" Digit clocks, the holes for the screws will be on the left and right inner surfaces of the housing. For 4.0" Digit Clocks, the holes will be on the top and bottom surfaces.

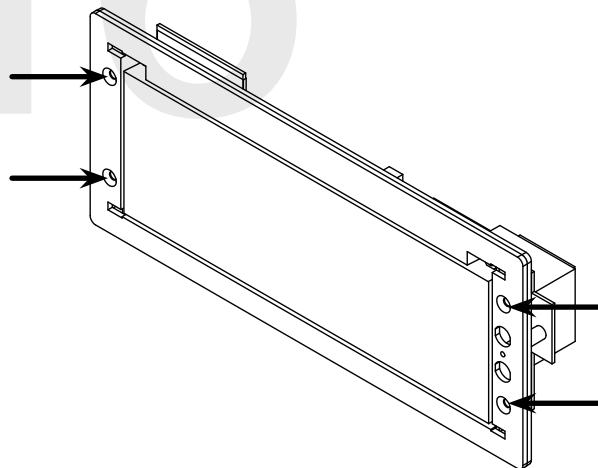

Flag Mount Installation

17) Use the 6-32x12 screws to attach the display board to the housing.

NOTE: For 2.5" Digit clocks, the holes for the screws will be on the left and right inner surfaces of the housing. For 4.0" Digit Clocks, the holes will be on the top and bottom surfaces.

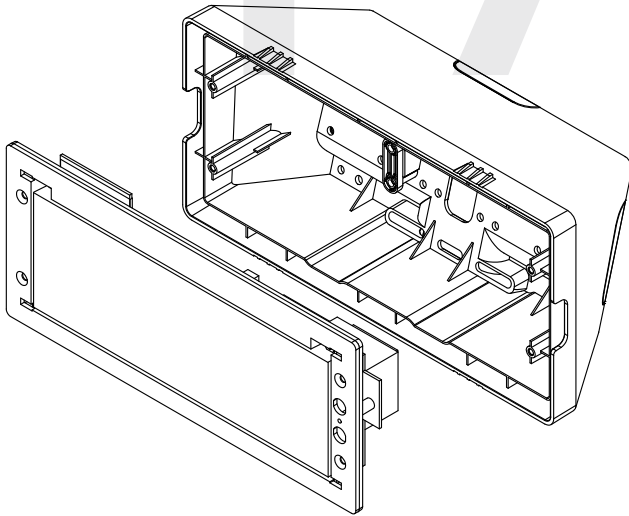

18) Remove the plastic cover from the display board.

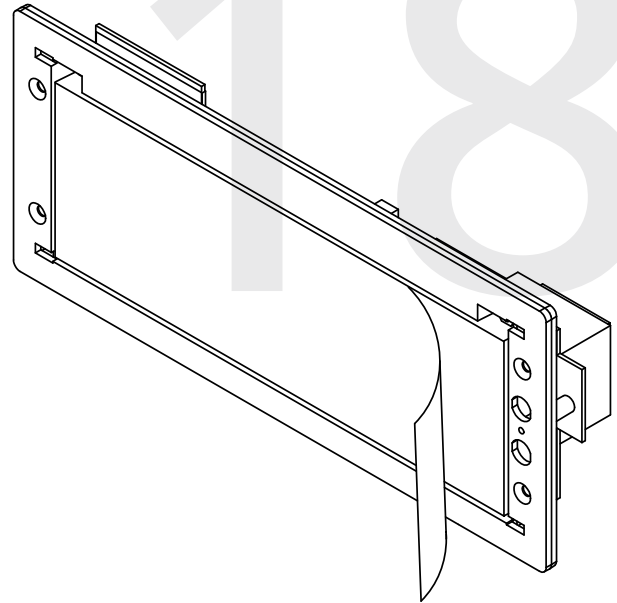

19) Place the filter over the display board. You should hear a snapping noise as the latches drop into place.

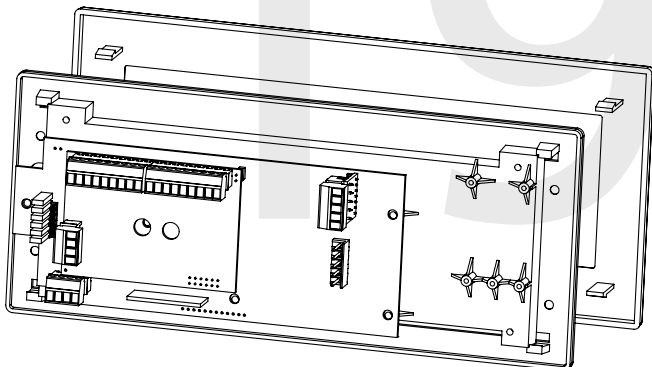

20) Place the housing frame onto the housing. You should hear a snapping noise as the latches drop into place.

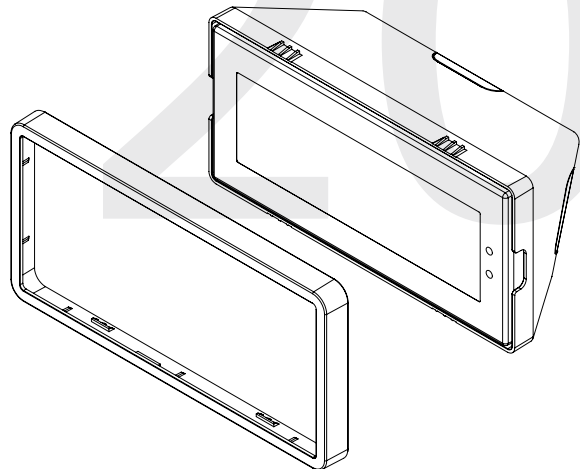

Flag Mount Installation



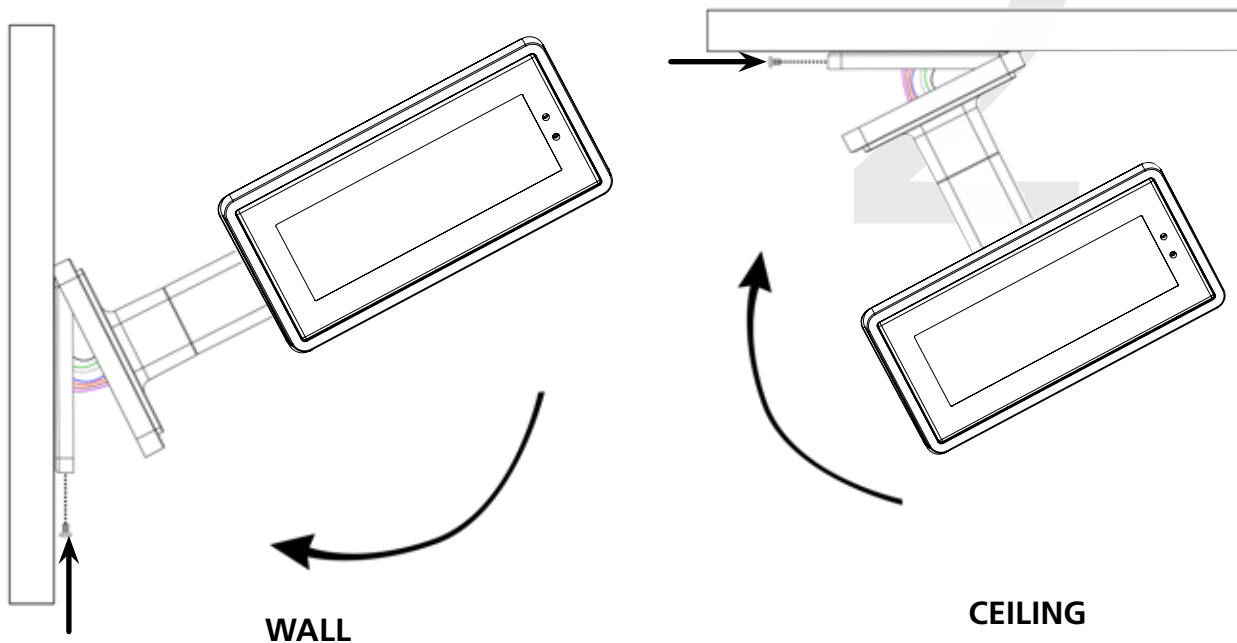

21) Hang the base of the pole on the mounting plate so that the lip is on top of the base, and the holes for the screws are on the bottom of the base. Attach the wires from the pole to the wires in the gang box, then use the two black base screws to attach the other side of the base to the mounting plate.

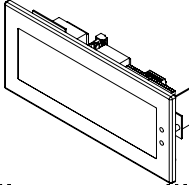
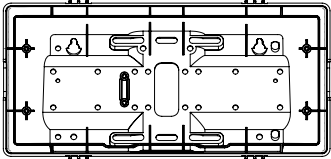
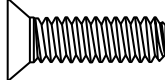

22) Power the clock. After testing the LED segments and presenting some diagnostic information, the clock will display the time based off of its internal quartz oscillator. It will correct itself to show synchronized time as soon as it receives data from a master clock.

Double Mount Installation

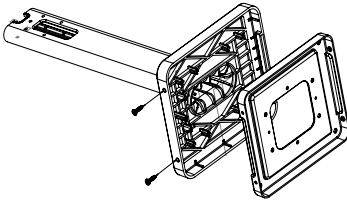
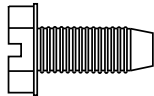
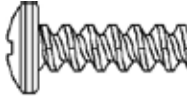
Included in Package

Description	Quantity	Picture
Valcom Digital Clock	1	
Digital Clock Wall Housing	1	
6-19x1/2 screw	8	
6-32x1 screw	8	
Included in Pole Kit (V-DMKIT)		
Dual-mount pole, including mounting plate	1	
#10-32x3/8 green screw	1	
#8-32x7/16 screw	8	
M3.5-1.0x10 screw (black)	4	
Internal-tooth washer	8	

Continued on next page

If any of the items listed in the kits are missing, you may contact Valcom and order a replacement kit.

Double Mount Installation

#6-32x1 screw

4



Adapter tab screws

4



Included in Wiring Kit (D-PK-3-110-S or D-PK-3-24-S) - 2 kits included

Power/grounding wires
and connector

1

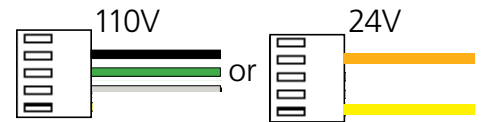

PLEASE NOTE: A user will also have to provide a Phillips-head screwdriver, a small flat-blade screwdriver, a single gang box, any equipment needed to install the gang box, and any additional wiring needed to extend the signal, power, or ground cables. You may also need a 1/4 inch drill, 4 #8x1.5 self-tapping screws, and 4 wall anchors for those screws if you decide not to attach the clock directly to the gang box.

If any of the items listed in the wiring kit are missing, you may contact Valcom and order a replacement kit.

Double Mount Installation

1) Install the double gang box in the wall or ceiling. If you are installing the gang box in the wall, leave at least eleven inches between the top of the gang box and the ceiling. If you are installing the gang box in the ceiling, leave at least eleven inches between the gang box and the wall. The box should be installed level and plumb with the wall and ceiling.

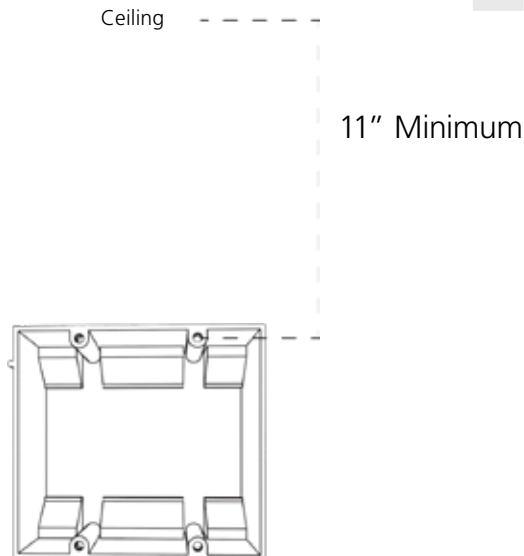

3) Detach the mounting plate from the mounting pole by unscrewing the two screws. Set the screws and pole aside for later.

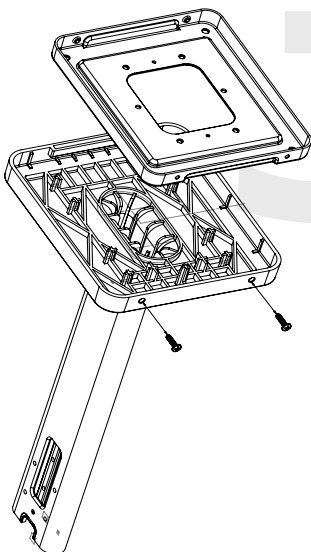

2) Run power and communication wiring to the gang box. See the sections of this manual labeled "Inputs - System Side" for additional details, depending on your system.

CHECK YOUR WIRING

The voltage between the white and black wires should measure 105-126 volts AC in the 110 volt model, or Yellow & orange wires for 21.5-26.5 volts DC in the 24 volt model.

If you are using the 24 volt model, make sure that the wiring leading to the clock is from a Valcom power supply or V-VCU.

4) Attach the mounting plate to the gang box using only two of the four long, silver #6-32x1 screws. With the mounting plate as a guide, use the pencil to trace the locations of the four larger holes at the outer corners.

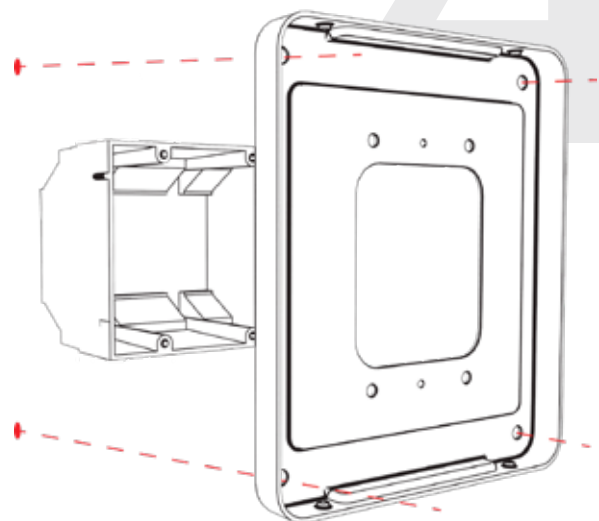

Double Mount Installation

5) Remove the mounting plate and drill the four holes that were just traced. Insert the four wall anchors into the holes.

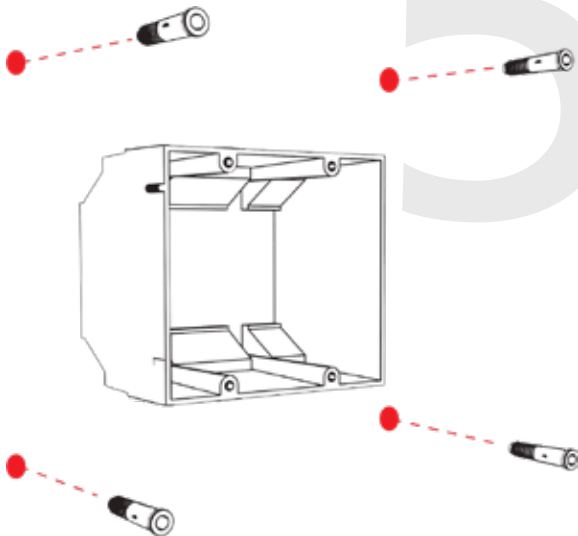

6) Reattach the mounting plate, this time using all four long, silver #6-32x1 screws, then insert the four #8 screws through the mounting plate and into the anchors.

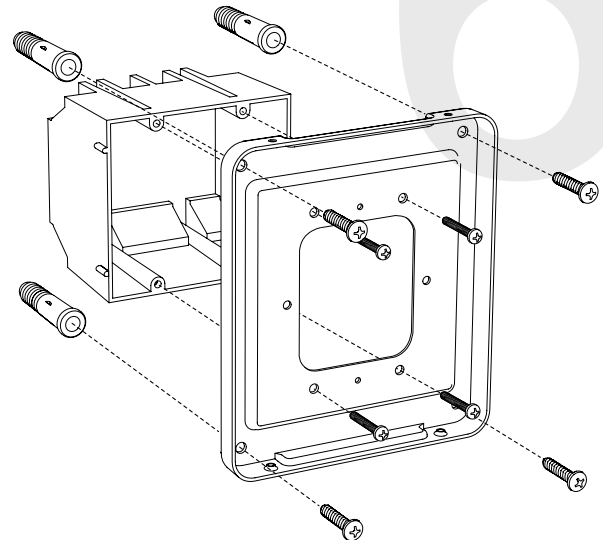

7) Thread any wiring through the mounting plate, and attach a grounding wire to the mounting plate using one of the larger centered holes and the #10-32x3/8 screw.

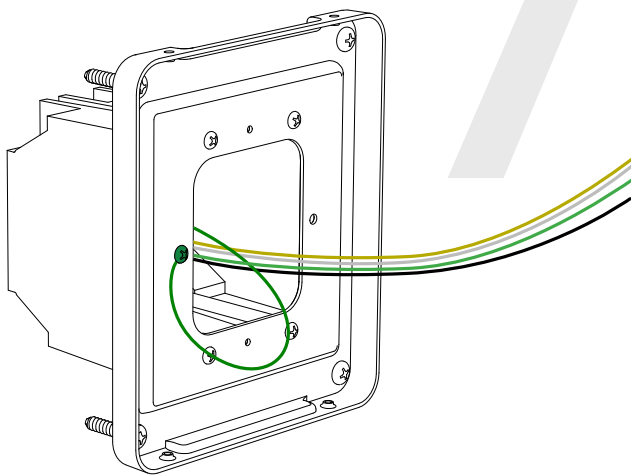

8) Use a screwdriver to remove one of the end caps. The selected end cap should match the position of the orientation of the clock on the mounting pole; for example, if you wish to attach the clock to the pole in a ceiling-mount configuration, then the top end cap should be removed. The end cap and screw that was used to secure it will not be needed again during this installation.

Double Mount Installation

9) Detach the frame from the front of each clock housing by pulling the bottom and top edges away from the housing.

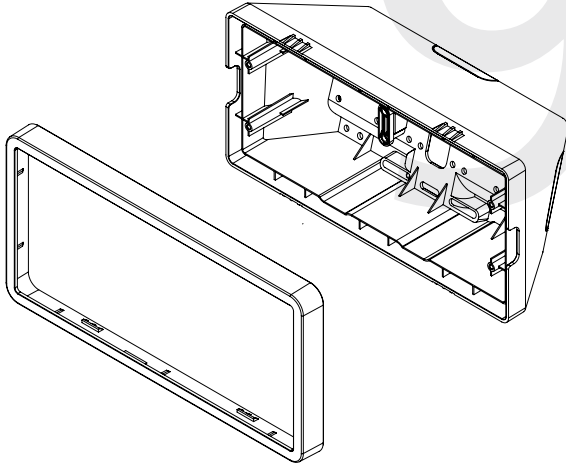

10) Insert the four #8-32x7/16 screws through the internal-tooth washers, then through each adapter, and finally into the pole. Use a screwdriver to tighten the screws so that the adapters do not move.

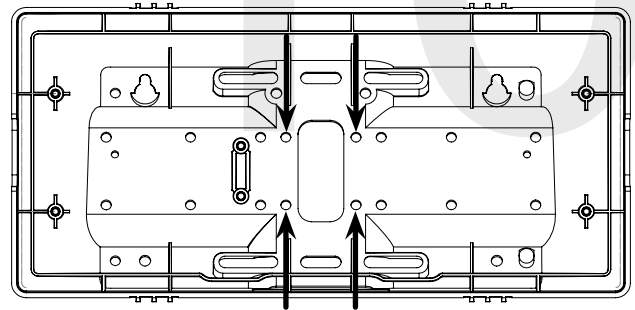

11) Attach adapters to each other using adapter tab screws, two on each side.

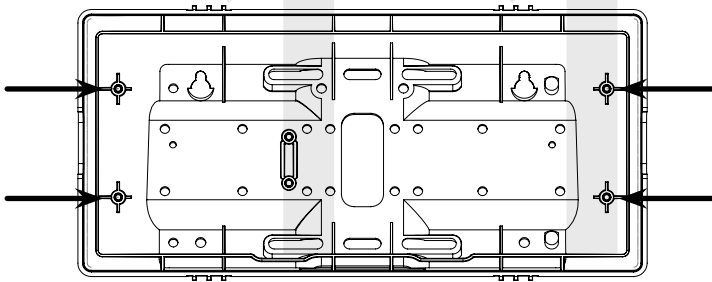

12) Thread at least fifteen inches (38.1cm) of wiring from the gang box through the bottom of the pole until each wire exits through the hole in each adapter. Secure the wires by passing them through the wire clamp.

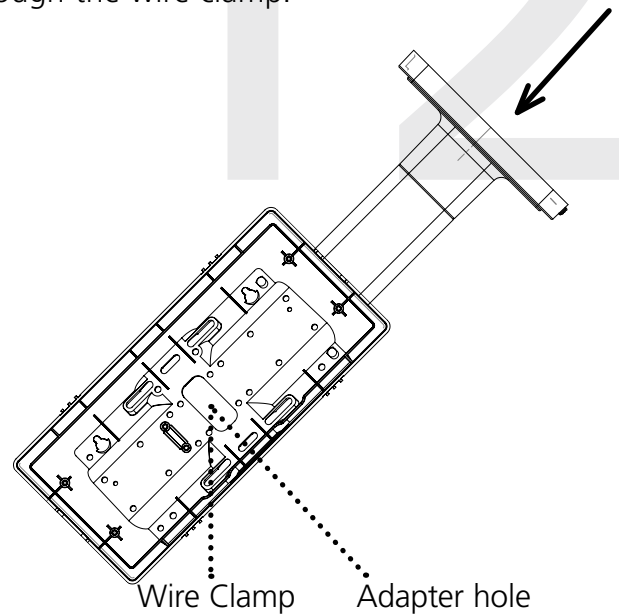

13) Detach the filter from the clock display board by pressing inward on the red tabs.

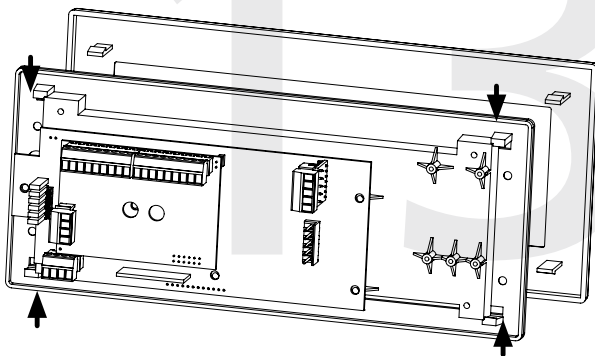

Double Mount Installation

13) Attach the signal and power wires from your kit to the wires you threaded through the poles. Consult the diagrams below for additional help, or see the sections of this manual labeled "3-Wire Synchronous (Sync-Wire) Communication Wiring Information" or "2-Wire Digital Communication Wiring Information" for additional details, depending on your system.

Please refer to the wiring guide

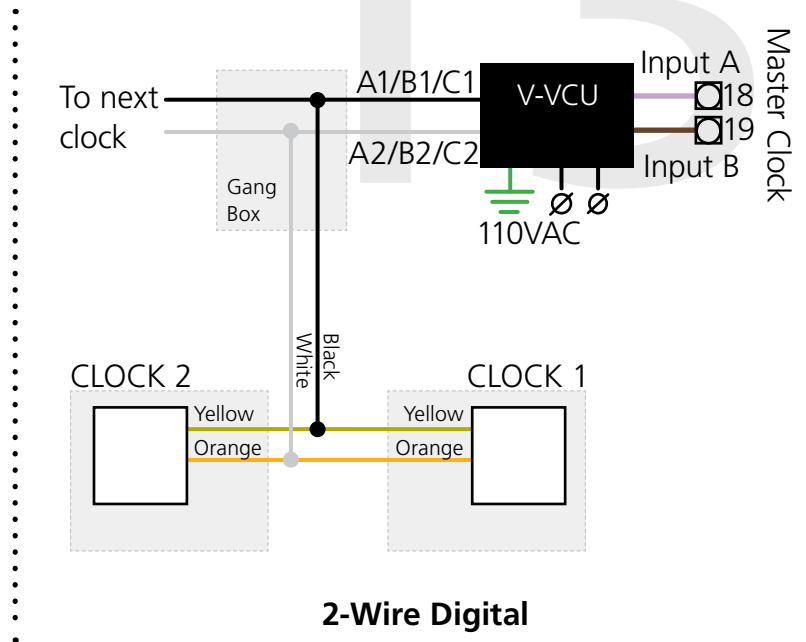

Double Mount Installation

14A) If you are installing digital clocks that use a 2-wire digital sync system, attach the wires to the port as shown below.

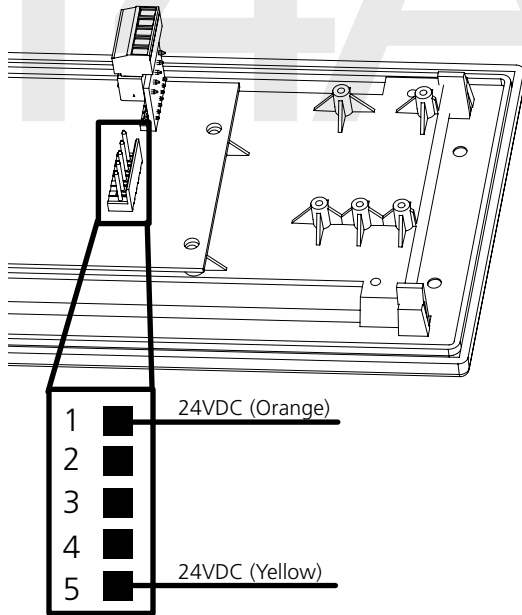

14C) If you are installing digital clocks that use sync-wire correction, attach the wires to the appropriate sync-wire ports. Refer to the section, "Inputs - Clock Side - Sync Wire" for instructions regarding each system.

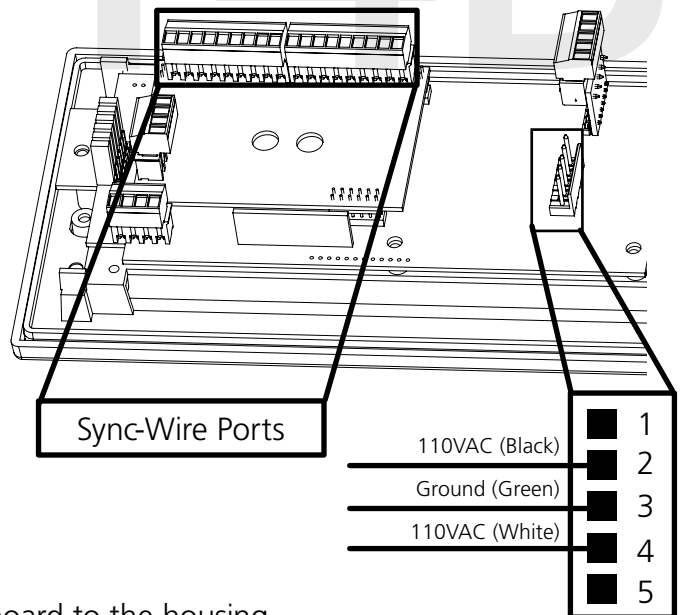

15) Use the M3/5-15x12 screws to attach each display board to the housing.

NOTE: For 2.5" Digit clocks, the holes for the screws will be on the left and right inner surfaces of the housing. For 4.0" Digit Clocks, the holes will be on the top and bottom surfaces.

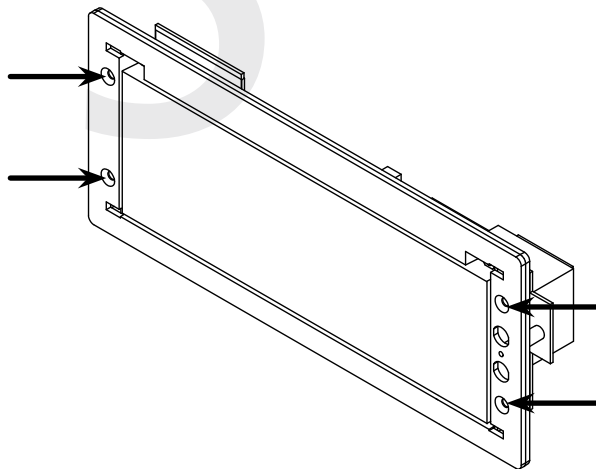

Double Mount Installation

16) Use the M3.5-1.5x12 screws to attach a display board to each housing.

NOTE: For 2.5" Digit clocks, the holes for the screws will be on the left and right inner surfaces of the housing. For 4.0" Digit Clocks, the holes will be on the top and bottom surfaces.

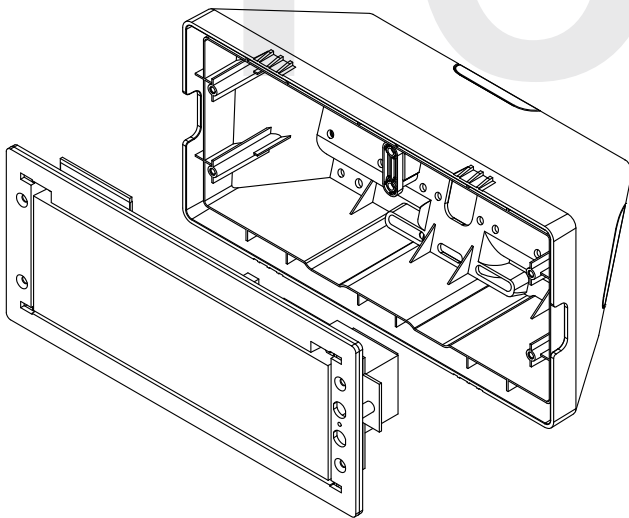

17) Remove the plastic cover from each display board.

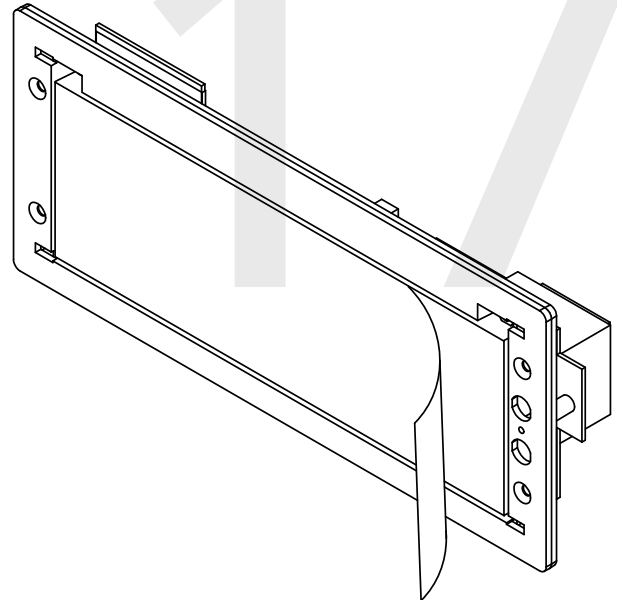

18) Place a filter over each display board. You should hear a snapping noise as the latches drop into place.

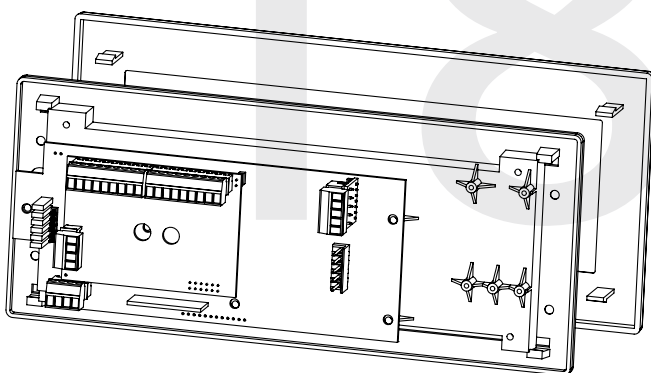

19) Place a housing frame onto each housing. You should hear a snapping noise as the latches drop into place.

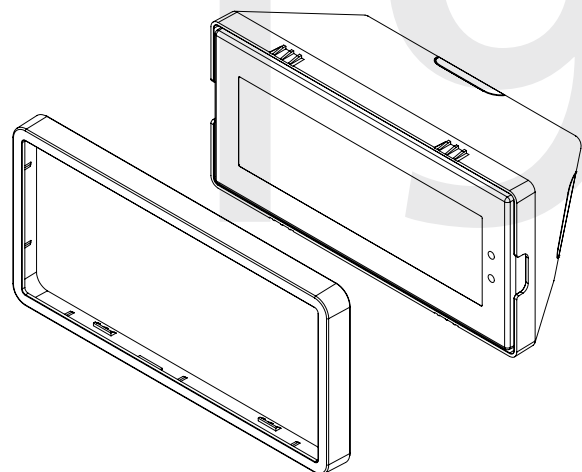

Double Mount Installation

20) Hang the base of the pole on the mounting plate so that the lip is on top of the base, and the holes for the screws are on the bottom of the base. Attach the wires from the pole to the wires in the gang box, then use the two black base screws to attach the other side of the base to the mounting plate.

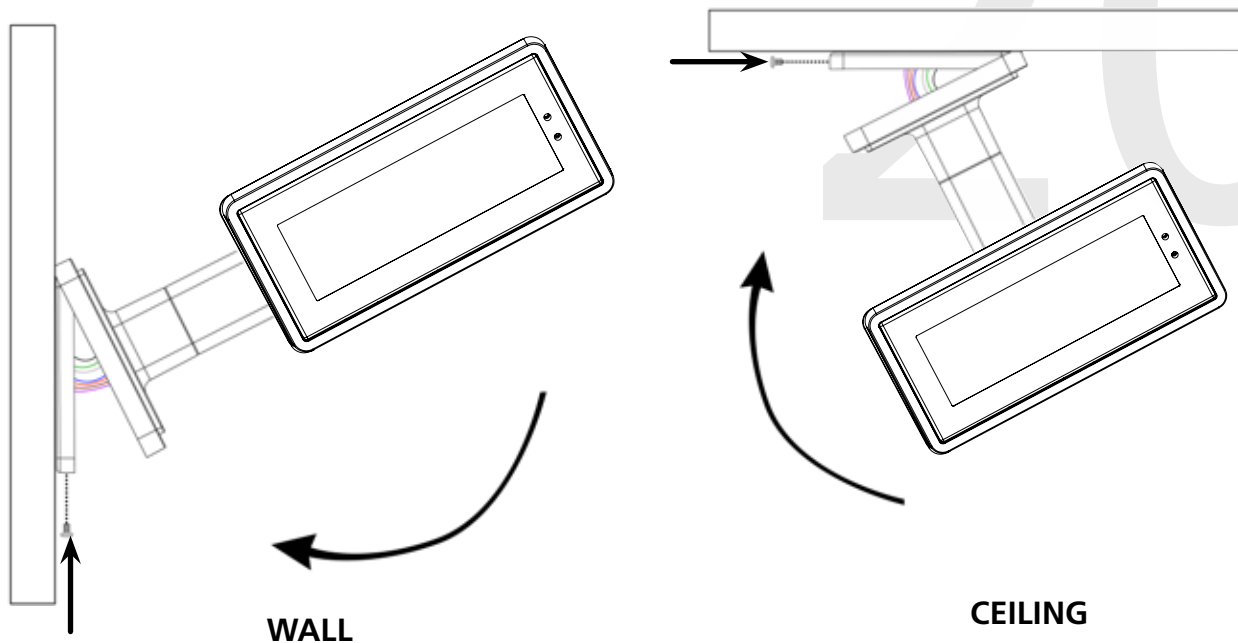

21) Power the clock. After testing the LED segments and presenting some diagnostic information, the clock will display the time based off of its internal quartz oscillator. It will correct itself to show synchronized time as soon as it receives data from a master clock.

Adjustable Jumper Settings

Every version of the digital clock contains a set of jumpers which can be moved to change a particular setting. The functions and positions of each jumper are described below:

	Left Position	Right Position
	Pins 1 & 2	Pins 2 & 3
Jumper 1	12 Hour Time (Default)	24 Hour Time
Jumper 2	Display High Brightness (Default)	Display Low Brightness
Jumper 3	Display Time Only (Default)	Alternate display between Time and Date
Jumper 4	DO NOT TOUCH (Default)	DO NOT TOUCH
Jumper 5	DO NOT TOUCH (Default)	DO NOT TOUCH
Jumper 6	Clock accepts sync-wire inputs (Default)	DO NOT USE

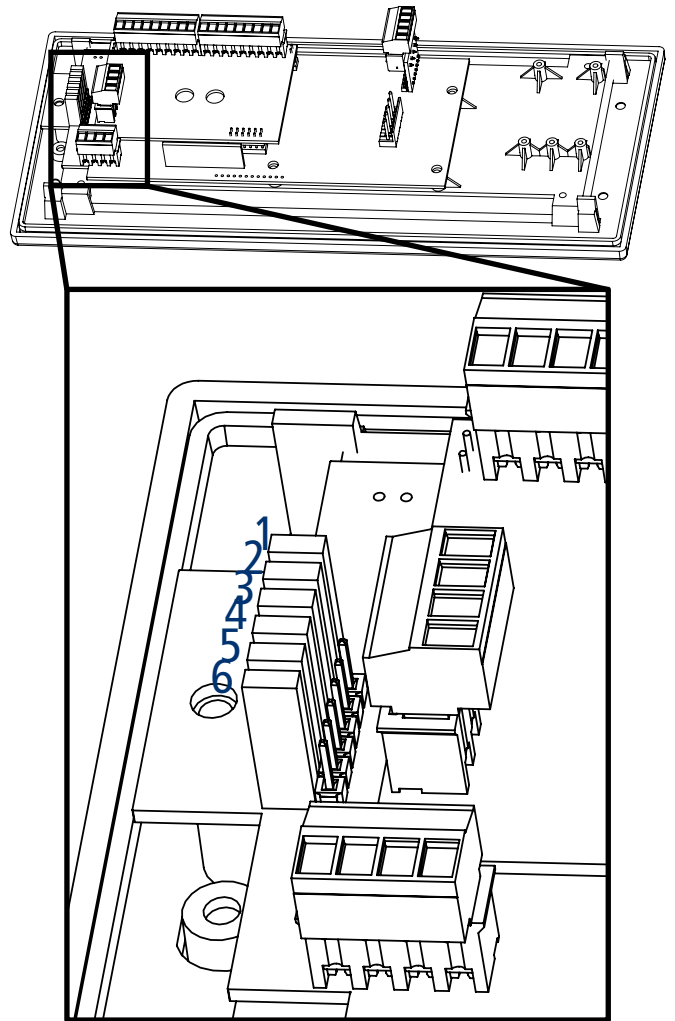

To manually enable or disable the first three jumpers, refer to the section of this manual labeled "Manual Controls" and refer to Setting 15.

Inputs - System-Side - 2-Wire Digital

Valcom Master Clock

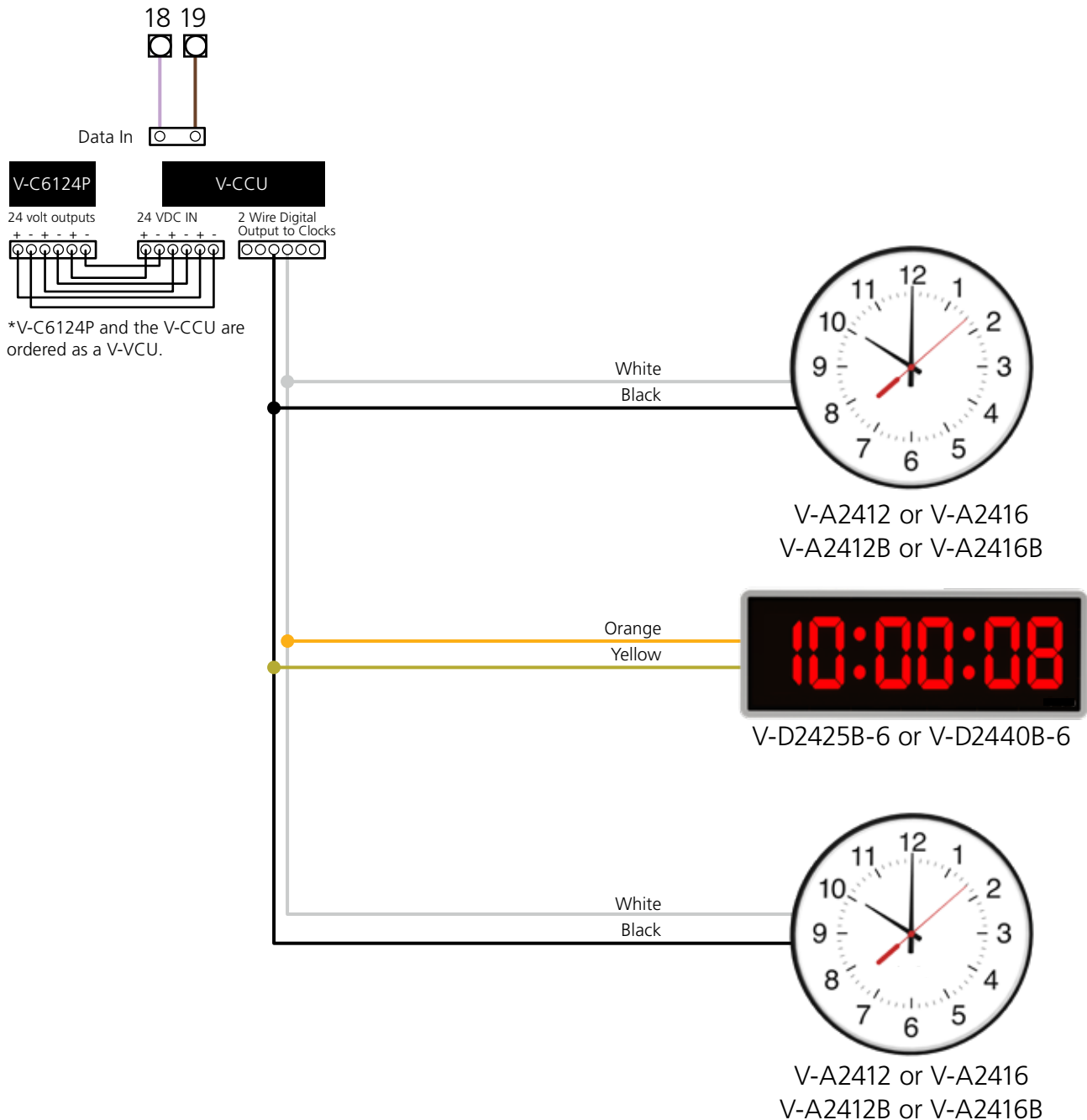

Inputs - System-Side - Sync-Wire 110VAC (V-D110XXB Only)

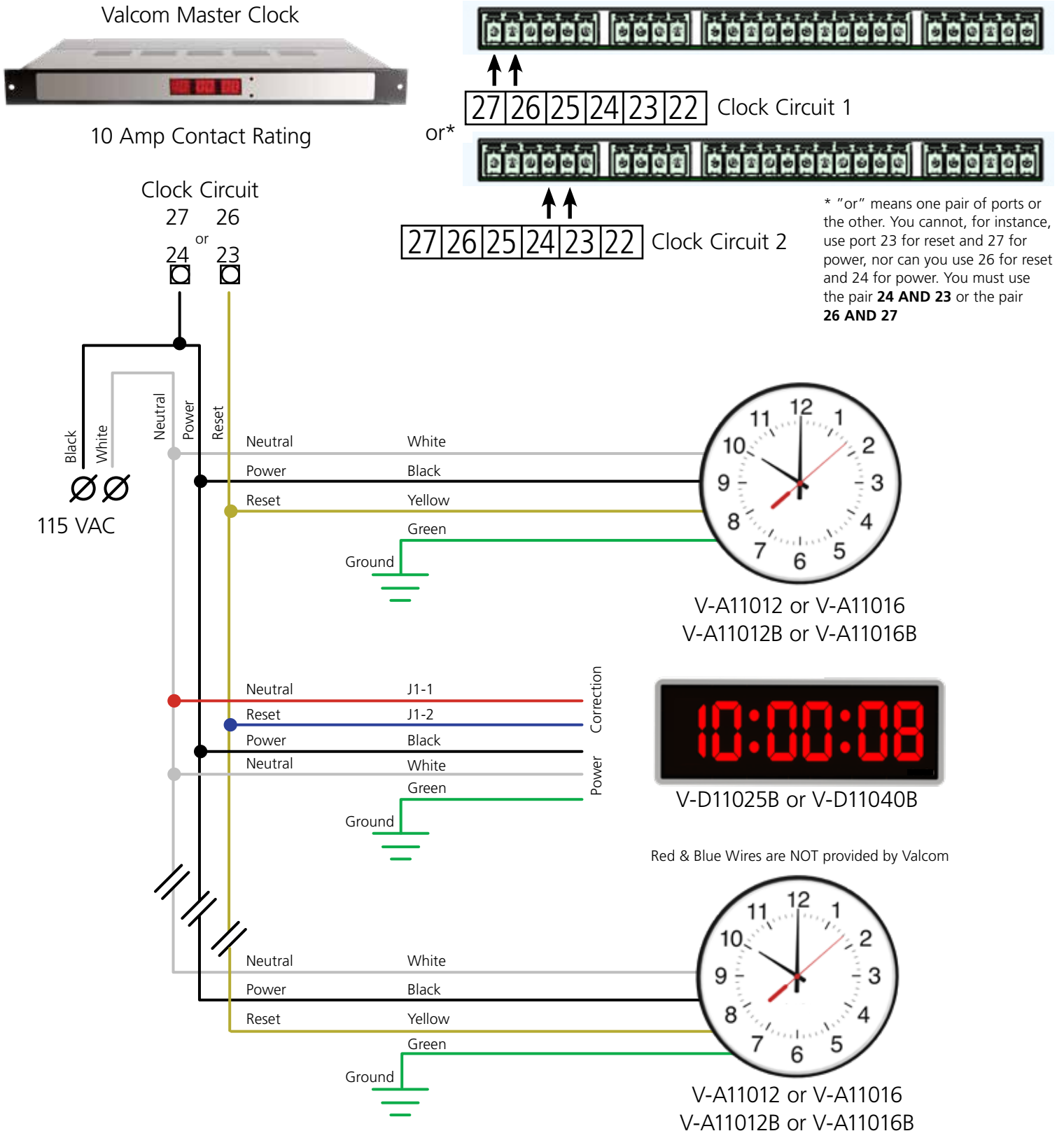

Inputs - Clock-Side - Sync-Wire (V-D110XXB Only)

Inputs for sync-wire protocols are located on the upper-port block on the back of the clock. For this manual, the ports in each block are listed as 1-9, starting with port 1 on the left, and ending with port 9 on the right.

There are two port blocks. In this manual, the block on the left will be called J1, while the block on the right will be called J2. Refer to the diagram for details.

The diagrams on the following pages indicate how wires should be run between the various ports on the clock and the network to allow for the use of Sync-wire protocols.

Before a clock can use these protocols, it must be configured to accept the intended protocol as its input through the front buttons. Refer to the sections "Manual Controls"

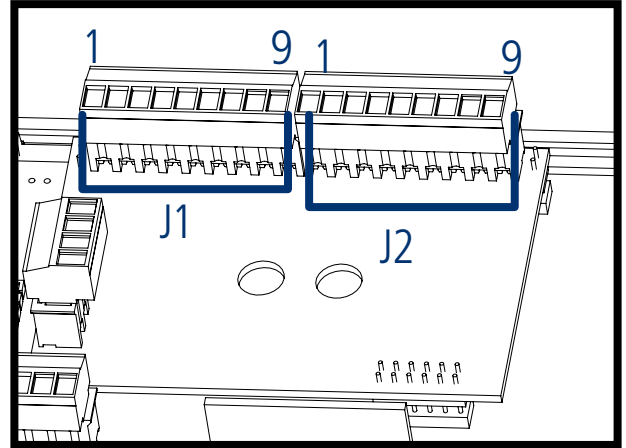

59 Minute Correction

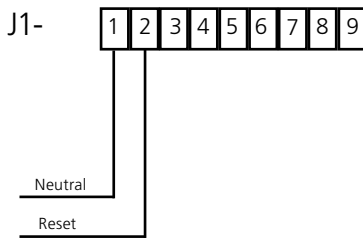

110VAC Interface

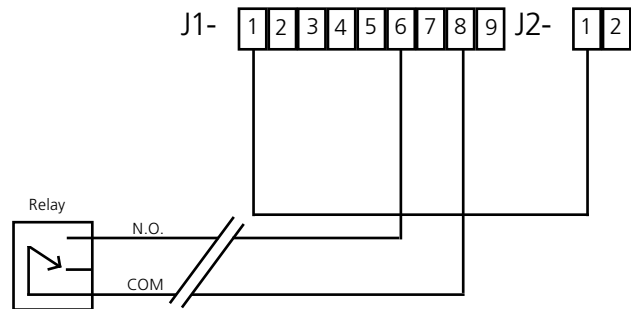

Dry Contact Closure

Description:

59 Minute Correction - 110VAC 60 Hz is used to run the clock normally. Applying an eight (8) second reset signal from 57 minutes and 54 seconds will cause an hourly correction. Applying a fourteen (14) second reset signal from 5:57:54 will cause a daily correction.

Inputs - Clock-Side - Sync-Wire (V-D110XXB Only)

58 Minute Correction

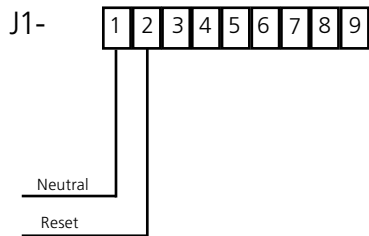

110VAC Interface

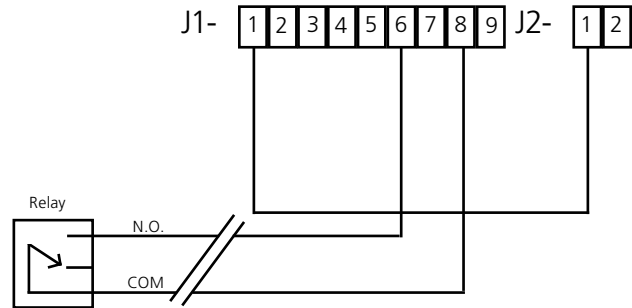

Dry Contact Closure

Description:

110VAC 60 Hz is used to run the clock normally. Refer to the table below for the four variations on 58 minute correction:

<p>58th minute (1) - The hourly correction for 55 seconds every hour from XX:58:05 to XX:59:00. The daily correction (5 a.m. & 5 p.m.) is ten correction cycles sent to the relay (each for 95 seconds) beginning at 5:05:00, 5:07:00, 5:09:00, 5:11:00, 5:13:00, 5:15:00, 5:17:00, 5:19:00, 5:21:00, and 5:23:00.</p>
<p>58th minute (2) - The hourly correction for 60 seconds every hour from XX:58:00 to XX:59:00. The daily correction (5 a.m. & 5 p.m.) is twelve correction cycles sent to the relay (each for 65 seconds on and 25 seconds off) beginning at 5:05:00 to 5:22:35.</p>
<p>58th minute (3) - The hourly correction for 60 seconds every hour from XX:58:00 to XX:59:00. The daily correction (5 a.m. & 5 p.m.) is twelve correction cycles sent to the relay (each for one minute on and two minutes off) beginning at 5:06:00.</p>
<p>58th minute (4) - The hourly correction for 55 seconds every hour from xx:58:05 to XX:59:00. The daily correction (5 a.m. & 5 p.m.) is 12 correction cycles for 55 seconds. The timings will be 05:03:05, 05:07:05, 05:11:05, 05:15:05, 05:19:05, 05:23:05, 05:27:05, 05:31:05, 05:35:05, 05:39:05, 05:43:05 and 05:47:05.</p>

Inputs - Clock-Side - Sync-Wire (V-D110XXB Only)

National Time/Rauland

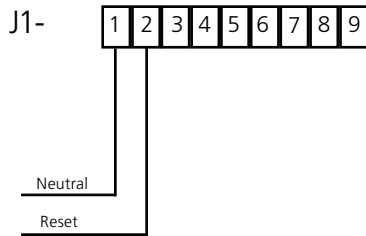

110VAC Interface

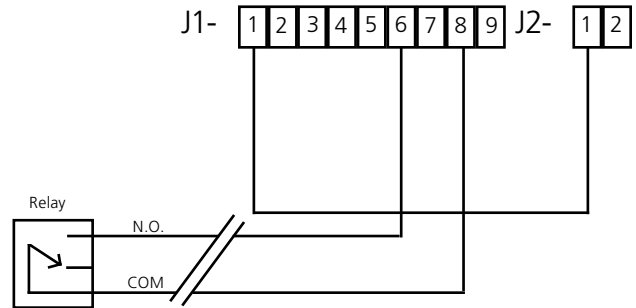

Dry Contact Closure

Description:

National Time/Rauland - 110VAC 60 Hz is used to run the clock normally. Applying a 25 second reset signal when minutes equal 00 and seconds equal 00 will cause an hourly correction. Applying a 24 minute reset signal when hours equal 06 or 18 and minutes equal 00 and second equals 25 will cause a daily correction.

Rauland Digital

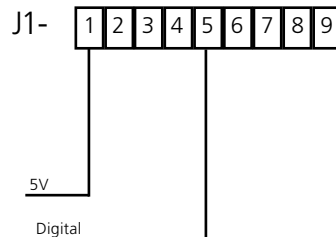

Description:

Rauland Digital - Applying a half second pulse for every minute to the Dig. Line will bring the clock to the correct time. The clock will jump to the correct time at the end of the correction pulse.

Note: For better synchronization, it is recommended to work on a 60 Hz time base.

Inputs - Clock-Side - Sync-Wire (V-D110XXB Only)

Dukane

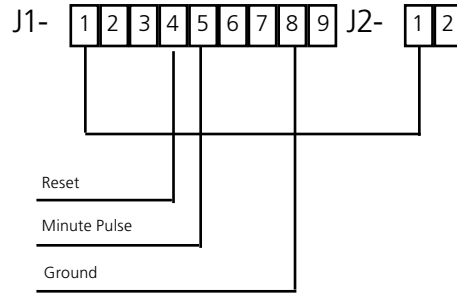

Description:

Dukane - Applying a 4-10 millisecond pulse on the minute line will increment the clock in one minute. Applying a 12-50 millisecond pulse on the reset line will bring the clock back to 12:00 a.m.

Midnight Reset or Once a Day Pulse

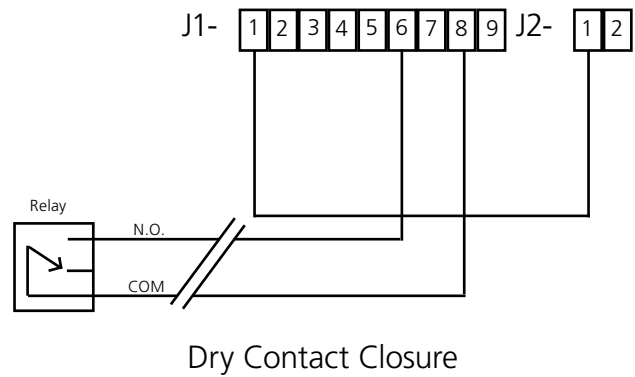
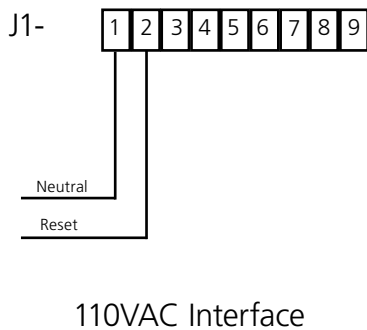

Description:

Midnight Reset or Once a Day Pulse - Applying a pulse for more than two (2) seconds will bring the clock to the correct time.

Outputs (V-D110XXB Only)

2-Wire Digital - Master Mode

During a loss of communication with the Master Clock, the V-D110XXB digital clock can act as a temporary, backup master clock for other clocks in the system. The port block on the bottom left side of the circuit board will be called J7. Refer to the diagram for details. For J7, the ports in the block are listed as 1-4, starting with port 1 on the left and port 4 on the right.

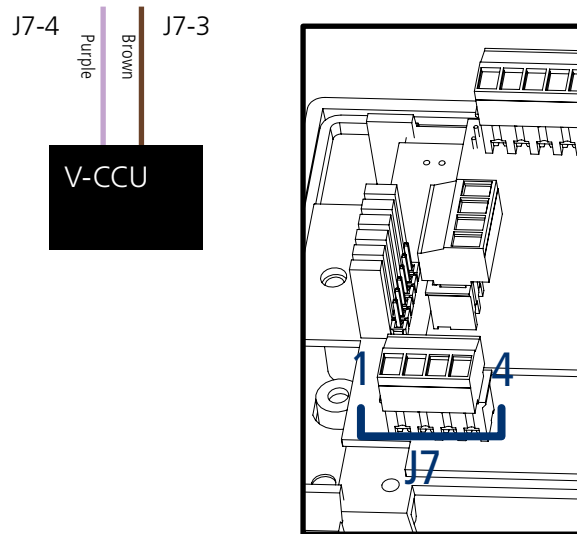

Output Relays

(IMPORTANT: Detach clock from power source before installing new circuitry. DO NOT add new circuitry while the clock is operating)

The port block on bottom left will be called J3. Refer to the diagram for details. For J3, the ports in the block are listed as 1-4, starting with port 1 on the bottom and port 4 on the top.

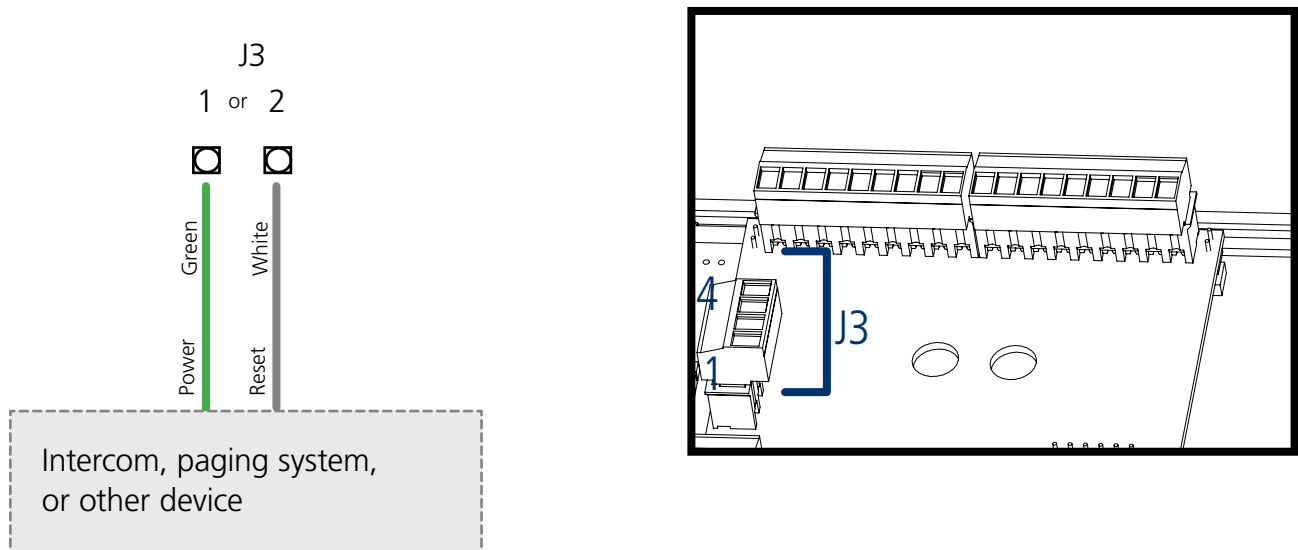

Manual Controls (V-D110XXB Only)

The purpose of this section is to get a new digital clock up and running using the manual controls on the front of the digital clock.

Although **we always recommend that the Digital Clock receive time data from an accurate time source**, if there is a need for the digital clock to act as a standalone device, the Digital Clock's internal real-time clock can be set manually. This can be done by pressing the top button to advance the hour, and the bottom button to advance the minute.

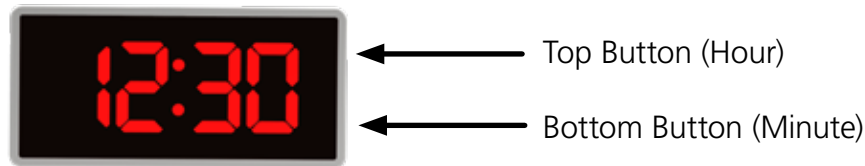

For all other settings, press and release both buttons simultaneously. To return the LED display to showing the time, repeatedly press the top button until all of the setting codes have been cycled through. The last code should be 41--99.

The numbers shown on the left are examples. Going down the list and entering every one of the examples exactly as shown will cause the clock to malfunction or use incorrect data. Program your clock setting based off of the instructions in the description on the right.

1 10

Setting 1 - Set Year

Use the bottom button to scroll from 00 through 99. This permits the user to select a year from 2000 to 2099.

2 11

Setting 2 - Set Month

Use the bottom button to scroll from 01 through 12. This permits the user to select a month from January (01) to December (12).

3 28

Setting 3 - Set Day of the Month

Use the bottom button to scroll from 01 through 31. This permits the user to select a day from the 1st of the month to the 31st of the month.

4 24

Setting 4 - 12/24 Hour Mode

Press the bottom button to switch between 12 and 24.

12 causes the master clock to display time in 12 Hour mode.

24 causes the master clock to display time in 24 Hour mode.

Manual Controls (V-D110XXB Only)

The numbers shown on the left are examples. Going down the list and entering every one of the examples exactly as shown will cause the clock to malfunction or use incorrect data. Program your clock setting based off of the instructions in the description on the right.

5 d

Setting 5 - Daylight Saving Time

Press the bottom button to switch between "d" or "E"

"d" disables Daylight Saving Time

"E" enables Daylight Saving Time

NOTE: Daylight Savings Time set through this method begins on the second Sunday of March at 2:00 AM, and ends on the first Sunday of November at 2:00 AM.

6 d

Setting 6 - Alternate Date and Time

Press the bottom button to switch between "d" or "E"

"d" disables Alternating Time and Date

"E" enables Alternating Time and Date

NOTE: Alternating Time and Date set through this method displays the time for seven seconds, then displays the date for three seconds, then repeats.

7 E

Setting 7 - Date Format

Allows the user to choose the Date format used when the clock is set to display alternating Date/Time. Press the bottom button to switch between "A" or "E"

"A" Stands for American Style - Month:Day:Year

"E" Stands for European Style - Day:Month:Year

On a 4-digit clock, only the day and month will be displayed.

8 02

Setting 8 - Display Brightness

Allows the user to choose the brightness level for the clock's main display.

Press the bottom button to cycle between values 00, 01, and 02. This values correspond to Low, Medium, and High (Default)

Manual Controls (V-D110XXB Only)

The numbers shown on the left are examples. Going down the list and entering every one of the examples exactly as shown will cause the master clock to malfunction or use incorrect data. Program your clock setting based off of the instructions in the description on the right.

9 1

Setting 9 - Clock I.D. Number

Press the bottom button to advance the ID number of the clock. This accepts the ID numbers 1 through 999.

The ID Number is used for displaying text messages like 911, bELL, and FirE. Consult the Master Clock manual for more information.

10 02

Setting 10 - Zone Number

Press the bottom button to advance the ID number of the clock. This accepts the Zone Numbers 01 through 99.

The Zone Number is used for displaying text messages like 911, bELL, and FirE. Consult the Master Clock manual for more information.

11 01

Setting 11 - Do not modify.

Do not modify this setting.

If the value is changed by accident, press the bottom button until this setting displays option 00.

13 E

Setting 13 - Enable Loss of Communication Alert

Press the bottom button to switch between "d" or "E"

"d" disables Loss of Communication Alert

"E" enables Loss of Communication Alert

When Loss of Communication Alert is enabled, the colons on the display will blink if the digital clock fails to synchronize with the master clock within a set amount of time. This amount of time is set through Setting 14.

Manual Controls (V-D110XXB Only)

The numbers shown on the left are examples. Going down the list and entering every one of the examples exactly as shown will cause the clock to malfunction or use incorrect data. Program your clock setting based off of the instructions in the description on the right.

14 06

Setting 14 - Loss of Communication Alert Additional Configuration

Allows the user to determine how much time should pass without a synchronization signal from the master clock before the Loss of Communication Alert is activated. Press the bottom button to switch between the numerical options below:

01 - Activates after 5 minutes	05 - Activates after 45 minutes	09 - Activates after 180 minutes
02 - Activates after 10 minutes	06 - Activates after 60 minutes	10 - Activates after 240 minutes
03 - Activates after 15 minutes	07 - Activates after 90 minutes	Note: Alert activates after signal loss for the time limit specified
04 - Activates after 30 minutes	08 - Activates after 120 minutes	

15 d

Setting 15 - Enable Circuit Board Jumpers

Press the bottom button to switch between "d" or "E"

"d" disables the jumpers

"E" enables the jumpers

NOTE: Enabling the jumpers overrides Settings 4, 6, and 8. Refer to the section of this manual labeled "Adjustable Jumper Settings" for information on the function of each jumper.

Manual Controls (V-D110XXB Only)

The numbers shown on the left are examples. Going down the list and entering every one of the examples exactly as shown will cause the clock to malfunction or use incorrect data. Program your clock setting based off of the instructions in the description on the right.

20

7

Setting 20 - **Set the Programmable Relay 1**

Press the bottom button to scroll from 1 to 9 or **d**. These numbers correspond to different protocols, specifically:

- 1) **58th Minute (1)** - The clock performs an hourly correction that takes 55 seconds and occurs between XX:58:05 and XX:59:00 of every hour. It also performs two daily corrections: one at 5:00AM and another at 5:00PM. Each daily correction is ten relay cycles, each cycle is 95 seconds long, and the cycles begin at 5:05AM/PM, 5:07, 5:09, 5:11, 5:13, 5:15, 5:17, 5:19, 5:21, and 5:23 respectively.
- 2) **58th Minute (2)** - The clock performs an hourly correction that takes 60 seconds and occurs between XX:58:00 and XX:59:00. It also performs two daily corrections: one at 5:00AM and one at 5:00PM. Each daily correction is made of twelve relay cycles, and each cycle consists of 65 seconds on and 25 seconds off
- 3) **58th Minute (3)** - The clock performs an hourly correction that takes 60 seconds and occurs between XX:58:00 and XX:59:00. It also performs two daily corrections: one at 5:00AM and one at 5:00PM. Each daily correction is made of twelve relay cycles, and each cycle consists of 60 seconds on and 120 seconds off.
- 4) **58th Minute (4)** - The clock performs an hourly correction that takes 55 seconds and occurs between XX:59:05 and XX:59:00. It also performs two daily corrections: one at 5:00AM and one at 5:00PM. Each daily correction is made of twelve relay cycles, each cycle is 55 seconds long, and the cycles begin at 5:03:05AM/PM, 5:07:05, 5:11:05, 5:15:05, 5:19:05, 5:23:05, 5:27:05, 5:31:05, 5:35:05, 5:39:05, 5:43:05, and 5:47:05 respectively.
- 5) **59th Minute** - The clock performs an hourly correction that takes 8 seconds and occurs between XX:57:54 and XX:58:02. It also performs two daily corrections: one at 5:00AM and one at 5:00PM. Each daily correction is a single 14 second pulse which lasts from 5:57:54 to 5:58:08.
- 6) **National time & Rauland (1)** - The clock performs an hourly correction that takes 25 seconds and occurs between XX:00:00 and XX:00:25. It also performs two daily corrections: one at 6:00AM and one at 6:00PM. Each daily correction is made of twenty four relay cycles consisting of 25 seconds on, followed by 35 seconds off.
- 7) **National Time & Rauland (2)** - The clock performs an hourly correction that takes 25 seconds and occurs between XX:00:00 and XX:00:25. It also performs two daily corrections at 6:00:25AM and 6:00:25PM. Each daily correction is a single 24 minute pulse which lasts from 6:00:25AM/PM to 6:24:25.
- 8) **Rauland Digital** - The clock will reset the secondary clock to 12:00:00AM, then advance the time on the secondary clock by one minute for every 0.5 seconds that the Digital line is shorted to ground.
- 9) **Once a Day Pulse** - The clock relay will close at a specific time and for an amount of time decided by the clock circuit settings (Settings 21-24 for circuit 1, or 26-29 for circuit 2).
- 10) **Disable Relay** - The relay is disabled. This is the default value for this function.

Manual Controls (V-D110XXB Only)

The numbers shown on the left are examples. Going down the list and entering every one of the examples exactly as shown will cause the clock to malfunction or use incorrect data. Program your clock setting based off of the instructions in the description on the right.

21 14

Setting 21 - Once a Day Pulse Output - Set Hour

This setting only appears if "8" was selected under Setting 20. Press the bottom button to scroll from 00 to 23. For example, a value of 13 is the same as 1:00PM. **Set to 0 by default.**

22 00

Setting 22 - Once a Day Pulse Output - Set Minutes

This setting only appears if "8" was selected under Setting 20. Press the bottom button to scroll from 00 to 59. **Set to 0 by default.**

23 30

Setting 23 - Once a Day Pulse Output - Set Seconds

This setting only appears if "8" was selected under Setting 20. Press the bottom button to scroll from 00 to 59. **Set to 0 by default.**

24 05

Setting 24 - Once a Day Pulse Output - Set Pulse Duration

This setting only appears if "8" was selected under Setting 20. Press the bottom button to scroll from 00 to 99. For example, a value of 98 will set a pulse duration of 1 minute and 38 seconds. **Set to 3 by default.**

30 1

Setting 30 - Set Sync Wire Time Input Type

Allows the user to configure the sync wire type used as an Input.

Press the bottom button to scroll from 1 to 9 or **d**. These numbers correspond to the different protocols listed below. **Set to 8 by default.**

d - Disable Auxiliary Input	01 - 58 Minute Correction (1)	02 - 58 Minute Correction (2)	09 - Once a Day Pulse
03 - 58 Minute Correction (3)	04 - 58 Minute Correction (4)	05 - 59 Minute Correction	
06 - National Time/Rauland	07 - Dukane Digital	08 - Rauland Digital	

31 14

Setting 31 - Once a Day Pulse Input - Clock #2 Circuit - Set Hour

This setting only appears if "8" was selected under Setting 20. Press the bottom button to scroll from 00 to 23. For example, a value of 13 is the same as 1:00PM. **Set to 0 by default.**

32 00

Setting 32 - Once a Day Pulse Input - Clock #2 Circuit - Set Minutes

This setting only appears if "8" was selected under Setting 20. Press the bottom button to scroll from 00 to 59. **Set to 0 by default.**

33 30

Setting 33 - Once a Day Pulse Input - Clock #2 Circuit - Set Seconds

This setting only appears if "8" was selected under Setting 20. Press the bottom button to scroll from 00 to 59. **Set to 0 by default.**

Manual Controls (V-D110XXB Only)

The numbers shown on the left are examples. Going down the list and entering every one of the examples exactly as shown will cause the clock to malfunction or use incorrect data. Program your clock setting based off of the instructions in the description on the right.

The settings below only apply to Valcom analog clocks using wired communication protocols such as 2-Wire Digital. The digital clock cannot send these commands to Wireless, IP or Wi-Fi clocks.

40 d

Setting 40 - Command Analog Clock to Perform Diagnostic

Allows the user to send a command to all analog clocks receiving data from this digital clock. The available commands are the diagnostic tests listed in the table below:

01 - Diagnostic 1 - Protocol Verification	03 - Diagnostic 3 - Resets clock to Manufacturing Default and sets all hands to 12	05 - Diagnostic 4 - Full Mechanical and Electrical Test. Begins automatically.
02 - Diagnostic 2 - Comprehensive Test	04 - Diagnostic 4 - Full Mechanical and Electrical Test. Press button on analog to start.	09 - Override diagnostic tests and return analog clocks to showing master clock time.
d - Does not send a command		

Details on the function of each diagnostic test can be found in the analog clock manual.

41 60

Setting 41 - Diagnostic Results Display Duration

This setting determines how long the results of a diagnostic test will remain on the face of an analog clock. Due to the nature of the tests, this time period only applies if values 01 or 02 were selected for Setting 40.

Press the bottom button to scroll from 00 to 99. For example, a value of 98 will set a display duration of 1 minute and 38 seconds.

Pressing the top button after Setting 41 will cause the clock to return to the normal time display.

Reading the Display

The digital clock is designed to display time in either a 12-hour or 24-hour format. When the display is set to the 12-hour format, a circular light will appear in the top left corner of the display to indicate PM, or disappear to indicate AM. When the display is set to the 24-hour format, the full 24-hour time will appear on the display; no other lights should appear.

Some examples:



The factory default setting for all digital clocks is the 12-hour format. If you wish to set the clock to display time in a 24-hour format, see the section labeled "Jumper Settings", included earlier in this manual.

Frequently Asked Questions

Can this digital clock be used as a standalone clock?

The Valcom Digital V-D110XXB can be used as a standalone clock, but it will not keep synchronized time in this configuration. Instead, it will rely on an internal quartz oscillator for keeping the time. The clock will drift by a few seconds each year while in this mode, and will need to be readjusted manually.

How can I use this digital clock with Rauland, Dukane and other systems?

V-D110XXB clocks can be added directly to several sync wire systems. Refer to the Inputs section of this manual for instructions on how to connect the clock to each system type.

V-D24XXB-6 clocks can obtain time from these systems through a master clock working as a translator. Data from the other system would be sent to the master clock, and then the master clock would send the data to the digital clocks through 2-wire or wireless communication protocols.

What happens to the digital clock if a power failure occurs?

If a power failure occurs, the display will shut off but the clock will continue to keep time with its internal quartz oscillator. This oscillator will continue to run on a tiny battery backup for about ten years. In this mode, it may drift from synchronized time by a few seconds for each year that the clock is without power. Once power is restored to the clock, the display will turn on and display the time on the quartz oscillator. It will correct this to accurate, synchronized time once a signal from a master clock is received.

What happens to the digital clock if contact with the time data source is lost?

The digital clock will rely on an internal quartz oscillator for keeping the time until time data is received. The clock will drift by a few seconds each year while in this mode, and will need to be readjusted manually.

The V-D110XXB digital clock is able to act as a master clock. If the communication input is lost to the V-D110XXB, and the V-D110XXB is acting as a master, then the clock will send synchronization data to any clocks down the line that are connected. This data will be based off of the V-D110XXB's quartz oscillator, so while the clocks will be synchronized to each other, they may not be showing accurate time.

How can I display "BELL" and "FirE" on the clock?

"FirE" and "BELL" are signals sent by the appropriate master clock. Refer to the master clock manual for instructions.

For 24V clocks, what happens if voltage on the power line drops from 24V to lower voltage?

The clock will still function, and will maintain the same level of brightness. However, the current consumption will increase proportionally to the decrease in voltage.

Troubleshooting

The clock is not running. What do I do?

1. Measure the input voltage to the clock. The voltage should measure 85-135 volts in the 120VAC model or 240VAC model or 10-28 volts in the 2.5"/24VDC model and 16-28 volt in the 4.0"/24VDC model.
2. Make sure the ground wire is not touching other wires.

NOTE: If you fail to follow instruction 2 the fuses can be blown.

The clock is not receiving an input signal. What do I do?

1. For V-D110XXB, Make sure that JP6 is in the proper position. Refer to "Adjustable Jumper Settings" for details and diagrams.
2. For V-D24XXB-6, Make sure that the polarity of the communication wire is correct when using the clock in 2-wire digital communication mode.
3. For V-D110XXB, make sure that the input voltage is zero when not applying a correction signal. When taking this measurement, you must be sure that the clock is disconnected from the master clock. Also, measure both AC & DC voltage. (The current consumption needed is very low, about 3mA, and a leakage current from the master clock can be interpreted as a continuous reset signal. If you are experiencing such a problem, please install a bypass mechanical relay).

Warranty

Valcom, Inc. warrants its products only to the original purchaser, for its own use, to be free from defects in materials and workmanship under conditions of normal use and service for a period of one year from the date of shipment. This Limited Warranty obligation shall be limited to the replacement, repair or refund of any such defective device within the warranty period, provided that:

1. Inspection by Valcom, Inc. indicates the validity of the claim;
2. The defect is not the result of damage, misuse or negligence after the original shipment;
3. The product has not been altered in any way or repaired by others and that factory sealed units are unopened (a service charge plus parts and labor will be applied to units defaced or physically damaged);
4. Freight charges for the return of products to Valcom are prepaid;
5. All units 'out of warranty' are subject to a service charge. The service charge will cover minor repairs (major repairs will be subject to additional charges for parts and labor).

This Limited Warranty is in lieu of and excludes all other warranties, expressed or implied and in no event shall Valcom, Inc. be liable for any anticipated profits, consequential damages, loss of time or other losses incurred by the buyer in connection with the purchase, operation, maintenance, installation, removal or use of the product. The maximum liability of Valcom under this warranty is limited to the purchase price of the specific Product covered by the warranty.

Disclaimer. Except for the Limited Warranty provided herein, the product is provided "as-is" without any warranty of any kind whatsoever including, without limitation, any WARRANTY OF MERCHANTABILITY, FITNESS FOR A PARTICULAR PURPOSE OR NON-INFRINGEMENT.

This warranty specifically excludes damage incurred in shipment. In the event a product is received in damaged condition, the carrier should be notified immediately. Claims for such damage should be filed with the carrier involved in accordance with the F.O.B. point.

Headquarters:

Valcom, Inc.

5614 Hollins Road

Roanoke VA 24019-5056

Phone: (540) 563-2000 FAX: (540) 362-9800