

## V-9885 Vandal-Resistant Dual Flexhorn One-Way INSTALLATION GUIDE

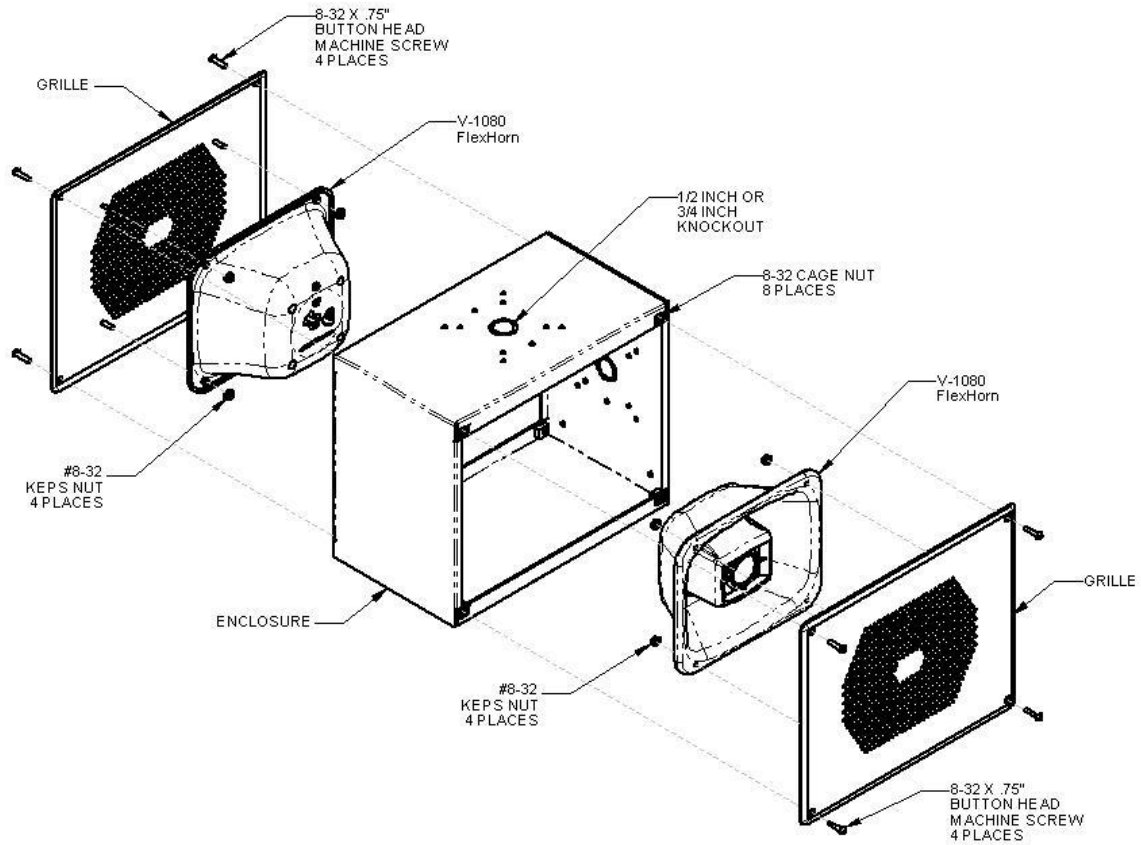

### DIMENSIONS/WEIGHT

- 10.00"H x 12.25"W x 7.38"D  
(25.4cm H x 31.12cm W x 18.7cm D)
- 12.1 lbs. (5.5 kg)

## INSTALLATION

Remove the speaker enclosure from the packing container. Using a Phillips screwdriver, remove the two screws securing each grille to the enclosure. Remove the grilles and remove any hardware packed inside the enclosure.

Pre-drilled 13/64" mounting holes in the side and top of the enclosure are designed to fit a single gang, double gang or octagon outlet box. If not attaching to an outlet box, use the enclosure as a template. Hold the enclosure in the desired position on the wall/ceiling and mark the location of mounting holes. Depending on wall/ceiling construction type, prepare the mounting hole locations on the wall/ceiling to securely attach the enclosure.

Wiring may be inserted through the knockout hole in the top or the side of the enclosure. Insert audio wires and power wires (if needed) through desired hole. Use mounting hardware (not included) appropriate for the wall/ceiling type to securely mount the enclosure to the wall/ceiling.

Connect the audio wires to the Green (Tip/A) and Red (Ring/B) leads on the Flexhorn speakers. Connect the power wires to the White (-24VDC) and Black (GND) leads on the Flexhorn speakers. The Flexhorns will have to

be removed from the grille assemblies (remove the four #8-32 KEPS nuts from each grille) to adjust the volume. The volume control is accessible on the front of the cone on the Flexhorn. After the volume is adjusted, attach the Flexhorns to the grille assemblies.

Align each grille/speaker assembly with the enclosure, and install the four supplied tamper-resistant screws through the grille into the enclosure. Use the supplied security hex bit to tighten the screws securely.

## TECHNICAL ASSISTANCE

Assistance is available from the factory when problems are encountered. Call (540) 563-2000 and press 1 for Technical Support or visit our website at <http://www.valcom.com>.

Valcom equipment is not field repairable. Valcom, Inc. maintains service facilities in Roanoke, VA. Should repairs be necessary, attach a tag to the unit clearly stating company name, address, phone number, contact person and the nature of the problem. Send the unit to:

**Valcom, Inc.**  
**Repair and Return Dept.**  
**5614 Hollins Road**  
**Roanoke, VA 24019-5056**

### VALCOM LIMITED WARRANTY

Valcom, Inc. warrants its products to be free from defects in materials and workmanship under conditions of normal use and service for a period of one year from the date of shipment. The obligation under this warranty shall be limited to the replacement, repair or refund of any such defective device within the warranty period, provided that:

1. inspection by Valcom, Inc. indicates the validity of the claim;
2. the defect is not the result of damage, misuse or negligence after the original shipment;
3. the product has not been altered in any way or repaired by others and that factory sealed units are unopened (a service charge plus parts and labor will be applied to units defaced or physically damaged);
4. freight charges for the return of products to Valcom are prepaid;
5. all units 'out of warranty' are subject to a service charge. The service charge will cover minor repairs (major repairs will be subject to additional charges for parts and labor).

This warranty is in lieu of and excludes all other warranties, expressed or implied and in no event shall Valcom, Inc. be liable for any anticipated profits, consequential damages, loss of time or other losses incurred by the buyer in connection with the purchase, operation or use of the product.

This warranty specifically excludes damage incurred in shipment. In the event a product is received in damaged condition, the carrier should be notified immediately. Claims for such damage should be filed with the carrier involved in accordance with the F.O.B. point.

Headquarters:  
Valcom, Inc.  
5614 Hollins Road  
Roanoke, VA 24019-5056  
Phone: (540) 563-2000