

VIP-429A-A-IC InformaCast® Compliant IP Talkback Speaker Clock Assembly

INTRODUCTION

The VIP-429A-A-IC InformaCast Compliant IP Wall Speaker with Clock enables voice access and visual time indication to a single zone of paging over an IP-based LAN/WAN. This allows page zone extension anywhere on the network. Clock synchronization is provided by the InformaCast server. The enclosure is made of steel with a durable powder coated finish. The color of the enclosure can easily be changed to match any decor. Power is provided to the VIP-429A-A-IC via a Power over Ethernet (PoE) switch meeting the 802.3af specification.



SPECIFICATIONS

Access Methods

- Singlewire InformaCast server
- PBX, FXO Port via Valcom FXS Network Station Port
- SIP – enabled telephone system
- POTS telephone set via Valcom FXS Network Station Port
- PBX, FXS Port via Valcom FXO Network Trunk Port
- Valcom Multicast Page Group

Features

- 802.3af compatible
- High efficiency Class-D amplifier

DIMENSIONS/WEIGHT

- 14.50" H x 13.00" W x 3.40" D
(36.93cm x 33.02cm W x 8.64cm D)
- Weight: 4.8 LBS (2.17 kg)

Environment

Temperature: 0 to +40° C
Humidity: 0 to 85% non-precipitating

Nominal Power Requirements

Via 802.3af PoE Ethernet Switch: Class 3

These products are intended for use with a UL Listed power source marked "Class 2" or "LPS" rated 24VDC, or 48VDC (PoE). PoE and all interconnected ITE are intended for intra-building.

Precautionary Designations

- **WARNING-To Reduce The Risk Of Fire Or Electric Shock. Do Not Expose This Apparatus To Rain Or Moisture.**
- **AVERTISSEMENT - Afin de réduire les risques d'incendie ou de décharge électrique, évitez d'exposer le système à la pluie ou à l'humidité.**
- **Apparatus shall not be exposed to dripping or splashing and no objects filled with liquids, such as vases, shall be placed on the apparatus.**
- **L'appareil ne doit pas être exposé à des égouttements et éclaboussures et aucun Objet Rempli de liquide, comme vase, ne doit être placé sur l'appareil.**

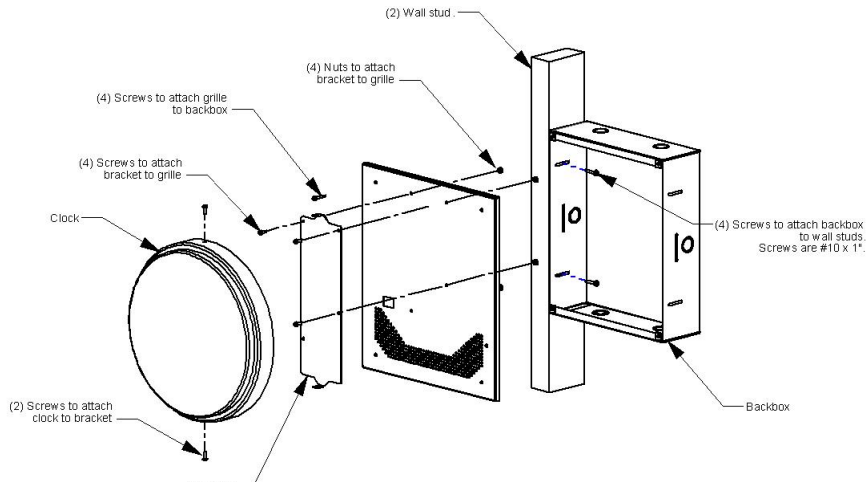

VB-R22

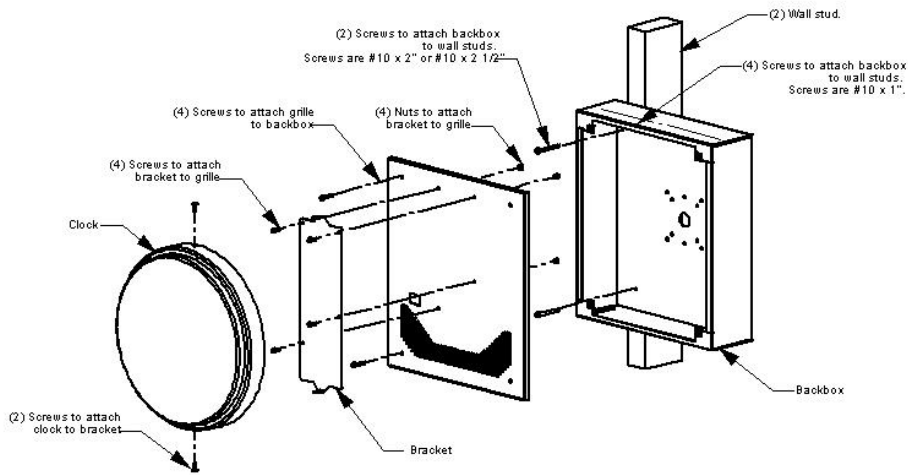

VB-S23

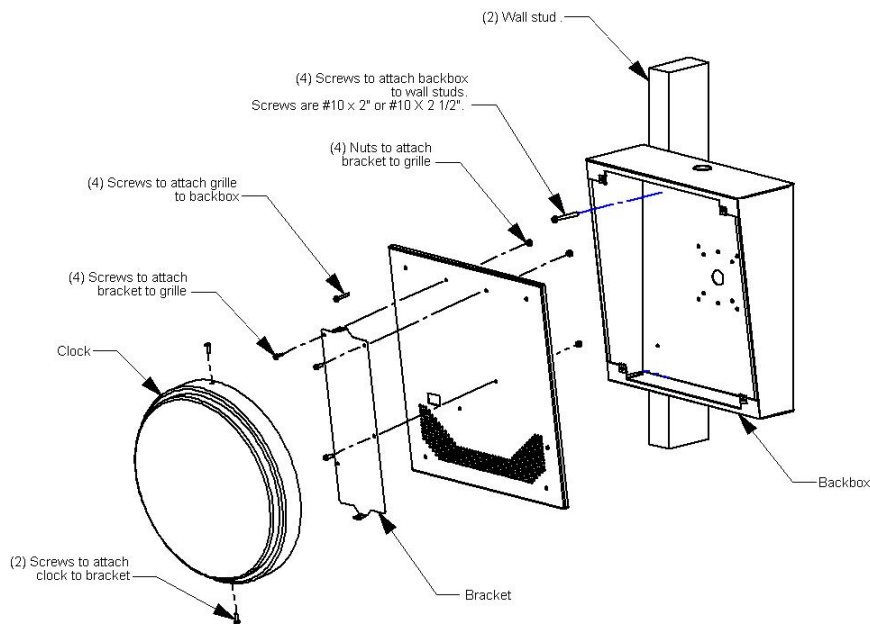

VB-A24

Figure 1. Assembly and Mounting

IMPORTANT SAFETY INFORMATION

CONSIGNES DE SÉCURITÉ IMPORTANTES

1. Read these instructions.
Lisez ces instructions.
2. Keep these instructions.
Conservez ces instructions.
3. Heed all warnings.
Respectez tous les avertissements.
4. Follow all instructions.
Suivez toutes les instructions.
5. Do not use this apparatus near water.
Ne pas utiliser cet appareil près de l'eau.
6. Clean only with dry cloth.
Nettoyer avec un chiffon sec.
7. Do not block any ventilation openings. Install in accordance with the manufacturer's instructions.
Ne pas bloquer les ouvertures de ventilation. Installer conformément aux instructions du fabricant.
8. Do not install near any heat sources such as radiators, heat registers, stoves or other apparatus (including amplifiers) that produce heat.
Ne pas installer à proximité de sources de chaleur telles que radiateurs, registres de chaleur, poêles ou autres appareils (y compris les amplificateurs) produisant de la chaleur.
9. Do not defeat the safety purpose of the polarized or grounding-type plug. A polarized plug has two blades with one wider than the other. A grounding type plug has two blades and a third grounding prong. The wide blade and the third prong are provided for your safety. If the provided plug does not fit into your outlet consult an electrician for replacement of the obsolete outlet.
Ne pas contourner le dispositif de sécurité de la fiche polarisée ou de mise à la terre. Une fiche polarisée possède deux lames dont une plus large que l'autre. Une fiche de terre a deux lames et une troisième broche de mise à la terre. La lame large et la troisième broche sont fournies pour votre sécurité. Si la fiche fournie ne rentre pas dans votre prise, veuillez consulter un électricien pour le remplacement de la prise obsolète.
10. Protect the power cord from being walked on or pinched particularly at plugs, convenience receptacles and the point where they exit from the apparatus.
11. Only use attachments/accessories specified by the manufacturer.
N'utilisez que des fixations / accessoires spécifiés par le fabricant.
12. Use only with the cart, stand, tripod, bracket or table specified by the manufacturer or sold with the apparatus. When a cart is used, use caution when moving the cart/apparatus combination to avoid injury from tip-over.

Utilisez uniquement avec le chariot, stand, trépied, support ou table spécifié par le fabricant ou vendu avec l'appareil. Quand un chariot est utilisé, Soyez prudent lorsque vous déplacez l'ensemble chariot / appareil pour éviter des blessures dues au renversement.
13. Unplug this apparatus during lightning storms or when unused for a long period of time.
Débranchez cet appareil pendant les orages ou lorsqu'il n'est pas utilisé pendant une longue période de temps.
14. Refer all servicing to qualified service personnel. Servicing is required when the apparatus has been damaged in any way. Such as when the power supply cord or plug is damaged, liquid has been spilled, objects have fallen into the apparatus or the apparatus has been exposed to rain or moisture and does not operate normally or has been dropped.
Confiez toute réparation à un personnel qualifié. Une réparation est nécessaire lorsque l'appareil a été endommagé de quelque façon. Par exemple lorsque le cordon d'alimentation ou la fiche est endommagé, du liquide a été renversé, si des objets sont tombés dans l'appareil ou que l'appareil a été exposé à la pluie ou à l'humidité et ne fonctionne pas normalement ou s'il est tombé.

This equipment generates, uses and can radiate radio frequency energy and if not installed and used in accordance with the instruction manual, may cause harmful interference to radio communications. Operation of this equipment in a residential area may cause harmful interference in which case the user will be required to correct the interference at one's own expense.

INSTALLATION Assembly and Mounting

The VIP-429A-A-IC is designed for recessed or flush mounting to a Valcom backbox (not included). For recessed mounting, the Valcom VB-R22 may be used. For surface mounting, use the Valcom VB-S23 or VB-A24.

Mount the clock face to the speaker grille using the clock mounting bracket included in the clock package (See Figure 1). The mounting bracket should be attached to the speaker grille using two screws and nuts provided, with the large rectangular cutout in the bracket aligned with the similar hole in the grille.

Before mounting the clock to the bracket, remove the shipping pin from the back of the clock movement. Connect the 5-pin Molex connector to the clock movement and route the wiring harness through one of the square cutouts in the speaker grille to the clock circuit board. Insert the 4-pin screw connector into the receptacle on the clock circuit board. Mount the clock face to the clock bracket with the two black screws provided





With the clock mounted to the speaker grille, connect an RJ-45 Ethernet cable to the network jack on the speaker circuit board, then mount the grille to the backbox with the hardware provided.

Network Connection

The VIP-429A-A-IC has one RJ-45 network connector on the rear panel. Use a standard patch cable to connect the VIP-429A-A-IC to an Ethernet switch providing Power over Ethernet (PoE) meeting the 802.3af specification. If the switch does not provide power, a mid-span power injector may be used. (See Figure 2)

Mute Out Connection

The Mute Out may optionally be connected to the mute input of Valcom Classroom audio management systems in order to suspend locally originated classroom audio during intercom announcements.

	CAUTION RISK OF ELECTRIC SHOCK DO NOT OPEN	
CAUTION: To reduce the risk of electric shock, Do not remove cover (or back). No user serviceable parts inside. Refer servicing to qualified service personnel.		
	This symbol indicates that dangerous voltage constituting a risk of electric shock is present within this unit.	
	This symbol indicates that there are important operating and maintenance instructions in the literature accompanying this unit.	

FCC Information

This equipment has been tested and found to comply with the limits for a Class A digital device, pursuant to Part 15 of the FCC Rules. These limits are designed to provide reasonable protection against harmful interference when the equipment is operated in a commercial environment.

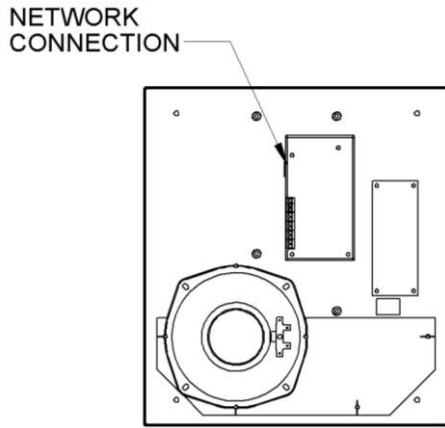

Figure 2. Ethernet Connection

Call Switch Connection

The Talkback IP Speaker provides a call switch input via screw terminal connections. Connect a momentary contact switch to Switch 1 and Ground. See Figure 3 for detailed connections.

-10 Db Line Level Out Connection

The -10dBm Line Level Out may be connected to up to 40 Valcom Self Amplified Speakers in order to provide additional sound reinforcement in an area.

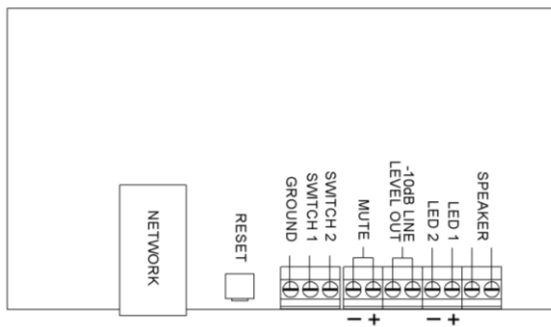

Figure 3. IP Speaker Connection

LED Connection

LED 1 (+) and LED 2 (-) is a current limited output designed to illuminate an optional LED. The LED is intended to provide visual indication of call progress. The LED illumination will flash when the call switch is pressed and will continue to flash until the call is answered. The LED illumination will be solid when a connection to the unit is established

Setup

The VIP-429A-A-IC will automatically acquire an IP address (using DHCP) and connect to the InformaCast server when connected to the network and powered up. Time synchronization is provided by the InformaCast server. Information specific to your application will need to be programmed into the InformaCast server. Refer to the InformaCast documentation for further information

TECHNICAL ASSISTANCE

When trouble is reported, verify power is being supplied to the unit and there are no broken connections. If a spare unit is available, substitute a spare unit for the suspected defective unit.

Assistance in troubleshooting is available from the factory. Call (540) 563-2000 and press 1 for Technical Support. When requesting assistance, you should include all available information. It is strongly suggested that you also review available documentation on <http://www.valcom.com>.

Valcom equipment is not field repairable. Valcom, Inc. maintains service facilities in Roanoke, VA. Should repairs be necessary, attach a tag to the unit clearly stating your company name, address, phone number, contact person and the nature of the problem. Send the unit to:

Valcom, Inc.
Repair & Return Dept.
5614 Hollins Road
Roanoke, Va. 24019-5056

WARRANTY

Warranty information may be found on our website at www.valcom.com/warranty