

## VIP-9815A-IC InformaCast® Compliant IP PoE CORRIDOR SPEAKER

### INTRODUCTION

The VIP-9815A-IC InformaCast Compliant IP PoE Corridor Speaker enables voice paging over an IP network. The VIP-9815A-IC consists of a high efficiency speaker in an unobtrusive, stylish enclosure.



### SPECIFICATIONS

#### Access Methods

- InformaCast Server
- SIP – enabled telephone system
- PBX, FXO Port via Valcom Enhanced Network Station Port
- POTS telephone set via Valcom Enhanced Network Station Port
- PBX, FXS Port via Valcom Enhanced Network Trunk Port
- Valcom Multicast Page Group

#### Features

- RJ-45 network connection
- Network activity LEDs
- Power over Ethernet (PoE) 802.3af Compatible

#### Nominal Power Requirements

Via 802.3af PoE Ethernet Switch: Class 3  
PSE (Power Sourcing Equipment) to be compliant to IEEE 802.3af

#### Dimensions & Weight

- 6.75 "H x 15.75 "W x 6.75 "D  
(17.1 cm x 40.0 cm x 17.1 cm)
- Weight: 5.2 lbs (2.35 kg)

#### Environment

Temperature: 0 to +40° C  
Humidity: 0 to 85% non-precipitating

#### Indoor Installation only

These products are intended for use with a UL Listed power source marked "Class 2" or "LPS" rated 24VDC, or 48VDC (PoE). PoE and all interconnected ITE are intended for intra-building.

#### Precautionary Designations

- **WARNING-To Reduce The Risk Of Fire Or Electric Shock. Do Not Expose This Apparatus To Rain Or Moisture.**
- **AVERTISSEMENT - Afin de réduire les risques d'incendie ou de décharge électrique, évitez d'exposer le système à la pluie ou à l'humidité.**
- **Apparatus shall not be exposed to dripping or splashing and no objects filled with liquids, such as vases, shall be placed on the apparatus.**
- **L'appareil ne doit pas être exposé à des égouttements et éclaboussures et aucun Objet Rempli de liquide, comme vase, ne doit être placé sur l'appareil.**



**IMPORTANT SAFETY INFORMATION**  
**CONSIGNES DE SÉCURITÉ IMPORTANTES**

1. Read these instructions.  
*Lisez ces instructions.*
2. Keep these instructions.  
*Conservez ces instructions.*
3. Heed all warnings.  
*Respectez tous les avertissements.*
4. Follow all instructions.  
*Suivez toutes les instructions.*
5. Do not use this apparatus near water.  
*Ne pas utiliser cet appareil près de l'eau.*
6. Clean only with dry cloth.  
*Nettoyer avec un chiffon sec.*
7. Do not block any ventilation openings. Install in accordance with the manufacturer's instructions.  
*Ne pas bloquer les ouvertures de ventilation. Installer conformément aux instructions du fabricant.*
8. Do not install near any heat sources such as radiators, heat registers, stoves or other apparatus (including amplifiers) that produce heat.  
*Ne pas installer à proximité de sources de chaleur telles que radiateurs, registres de chaleur, poêles ou autres appareils (y compris les amplificateurs) produisant de la chaleur.*
9. Do not defeat the safety purpose of the polarized or grounding-type plug. A polarized plug has two blades with one wider than the other. A grounding type plug has two blades and a third grounding prong. The wide blade and the third prong are provided for your safety. If the provided plug does not fit into your outlet consult an electrician for replacement of the obsolete outlet.  
*Ne pas contourner le dispositif de sécurité de la fiche polarisée ou de mise à la terre. Une fiche polarisée possède deux lames dont une plus large que l'autre. Une fiche de terre a deux lames et une troisième broche de mise à la terre. La lame large et la troisième broche sont fournies pour votre sécurité. Si la fiche fournie ne rentre pas dans votre prise, veuillez consulter un électricien pour le remplacement de la prise obsolète.*
10. Protect the power cord from being walked on or pinched particularly at plugs, convenience receptacles and the point where they exit from the apparatus.
11. Only use attachments/accessories specified by the manufacturer.  
*N'utilisez que des fixations / accessoires spécifiés par le fabricant.*
12. Use only with the cart, stand, tripod, bracket or table specified by the manufacturer or sold with the apparatus. When a cart is used, use caution when moving the cart/apparatus combination to avoid injury from tip-over.  
*Utilisez uniquement avec le chariot, stand, trépied, support ou table spécifié par le fabricant ou vendu avec l'appareil. Quand un chariot est utilisé, Soyez prudent lorsque vous déplacez l'ensemble chariot / appareil pour éviter des blessures dues au renversement.*
13. Unplug this apparatus during lightning storms or when unused for a long period of time.  
*Débranchez cet appareil pendant les orages ou lorsqu'il n'est pas utilisé pendant une longue période de temps.*
14. Refer all servicing to qualified service personnel. Servicing is required when the apparatus has been damaged in any way. Such as when the power supply cord or plug is damaged, liquid has been spilled, objects have fallen into the apparatus or the apparatus has been exposed to rain or moisture and does not operate normally or has been dropped.  
*Confiez toute réparation à un personnel qualifié. Une réparation est nécessaire lorsque l'appareil a été endommagé de quelque façon. Par exemple lorsque le cordon d'alimentation ou la fiche est endommagé, du liquide a été renversé, si des objets sont tombés dans l'appareil ou le appareil a été exposé à la pluie ou à l'humidité et ne fonctionne pas normalement ou s'il est tombé.*



## FCC Information

This equipment has been tested and found to comply with the limits for a Class A digital device, pursuant to Part 15 of the FCC Rules. These limits are designed to provide reasonable protection against harmful interference when the equipment is operated in a commercial environment.

This equipment generates, uses and can radiate radio frequency energy and if not installed and used in accordance with the instruction manual, may cause harmful interference to radio communications. Operation of this equipment in a residential area may cause harmful interference in which case the user will be required to correct the interference at his own expense.

## INSTALLATION

### Mounting

For enhanced protection against static electrical discharge, it is recommended the VIP-9815A-IC be installed onto a grounded electrical box. If surface mounted, ground the box to local ground.

The VIP-9815A-IC speaker enclosure is designed for double gang FD electrical box mounting and must be within 100 meters of the network switch.

Remove the speaker assembly from the packing container. Using a Phillips screwdriver, remove the screws securing the front grille to the speaker housing. Remove the screws holding the mounting bracket from the back of the speaker housing. Pre-drilled 13/64" mounting holes in the mounting bracket are designed to fit a single gang, double gang or octagon outlet box. If not attaching to an outlet box, use the mounting bracket as a template. Hold the mounting bracket in the desired position on the wall and mark the location of mounting holes. Depending on wall construction type, prepare the mounting hole locations on the wall to securely attach the mounting bracket. (See Figure 1)

Before installing the speaker housing to the mounting bracket, route the Ethernet patch cable from the network switch to the speaker through the large hole in the back of the mounting bracket, then through the slot behind the speaker in the speaker housing.

Align the speaker housing assembly with the mounting bracket and secure with four screws into the mounting bracket. Insert the RJ45 connector from the Ethernet patch cable into the RJ45 jack on the circuit board. After making the network connection, align the front grille with the speaker housing and secure with 8 screws.

## Power Connections

The only method of powering a VIP-9815A-IC Network Interface is via a Power over Ethernet (PoE) switch or power injector meeting the 802.3af specification.

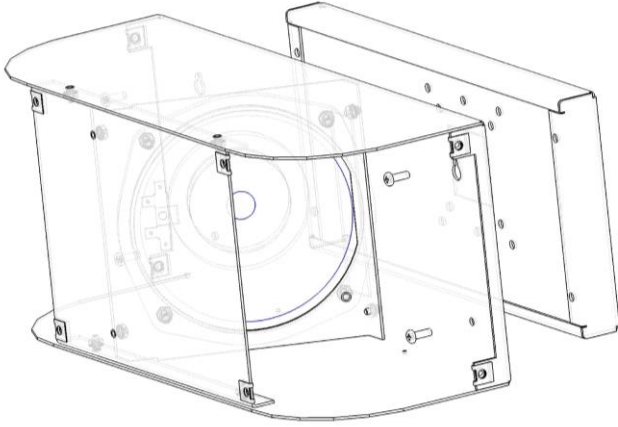

Figure 1. Mounting

## Network Connection

The VIP-9815A-IC has one RJ-45 Network connector. Insert the RJ45 cable connector into the RJ45 network jack mounted inside the speaker housing before attaching the front grille to the speaker housing.

## Signal Connections

Signal connections between the network interface and the speaker are pre-wired from the factory. If the speaker connections have been removed, connect the speaker leads to the Speaker (+) and Speaker (-) screw terminals on the network interface.

## Status Indicator Lights

The VIP-9815A-IC has 2 status indication lights located on the network jack:

**Green LED:** (Link) Indicates Ethernet connection when illuminated.

**Yellow LED:** (Activity) Indicator flashes to indicate network activity.

## Setup

The VIP-9815A-IC will automatically acquire an IP address (using DHCP) and connect to the InformaCast server when connected to the network and powered up. Information specific to your application will need to be programmed into the InformaCast server. Refer to the InformaCast documentation for further Information.

## TECHNICAL ASSISTANCE

Assistant is available from the factory. Call (540) 563-2000 and press 1 for Technical Support or visit our website at <http://www.valcom.com>

Valcom equipment is not field repairable. Valcom, Inc. maintains service facilities in Roanoke, VA. Should repairs be necessary, attach a tag to the unit clearly stating company name, address, phone number, contact person and the nature of the problem. Send the unit to:

**Valcom, Inc.**  
**Repair and Return Dept.**  
**5614 Hollins Road**  
**Roanoke, VA 24019**

## WARRANTY

Warranty information may be found on our website at [www.valcom.com/warranty](http://www.valcom.com/warranty).