

VP-1124A/VP-1124A-EC/VP-1124A-UK POWER SUPPLY

SPECIFICATIONS

- Input: 100-250VAC, 50/60Hz
IEC 320 input receptacle
- Output: 24VDC, 1A Regulated
5.5mm x 2.5mm connector center
positive (mating wire assembly
included)
- Dimensions: 4.125" H x 1.625" W x 1.375" D
(102mm H x 40mm W x 30mm D)
- Weight: 0.9 lbs. (0.4 kg)
- Mounting: Wall or shelf, mount near an
electrical outlet (wall mount
hardware included)
- Features: Output voltage indicator



FOR INDOOR USE ONLY

OUTPUT CONNECTIONS

- Connect "+" wire to connection labeled GND on Valcom equipment
- Connect "-" wire to connection labeled -24V on Valcom equipment

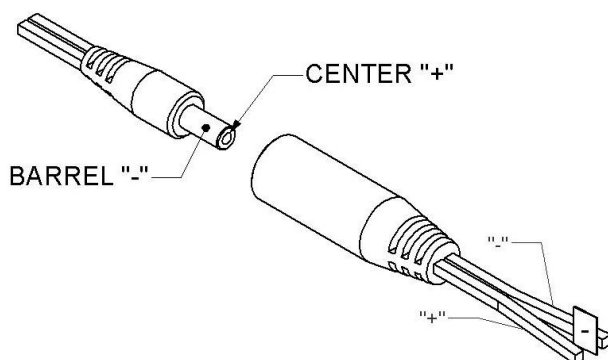

REGULATORY INFORMATION

UL, cUL and CE Approvals
Meets VDE and FCC Class B Regulations

TECHNICAL ASSISTANCE

When trouble is reported, verify that AC power is being supplied to the unit. To test the power supply, remove all output connections, and measure the output voltage with a meter. If no voltage is measured, replace the unit.

Assistance in troubleshooting is available from the factory. When calling, you should have a VOM and a test set available and be calling from the job site. Call (540) 563-2000 and ask for Technical Support, or visit our website at <http://www.valcom.com>.

Valcom equipment is not field repairable. Valcom, Inc. maintains service facilities in Roanoke, VA. Should repairs be necessary, attach a tag to the unit clearly stating your company name, address, phone number, contact person and the nature of the problem. Send the unit to:

Valcom, Inc.
Repair and Return Dept.
5614 Hollins Road
Roanoke, VA 24019-5056

MOUNTING

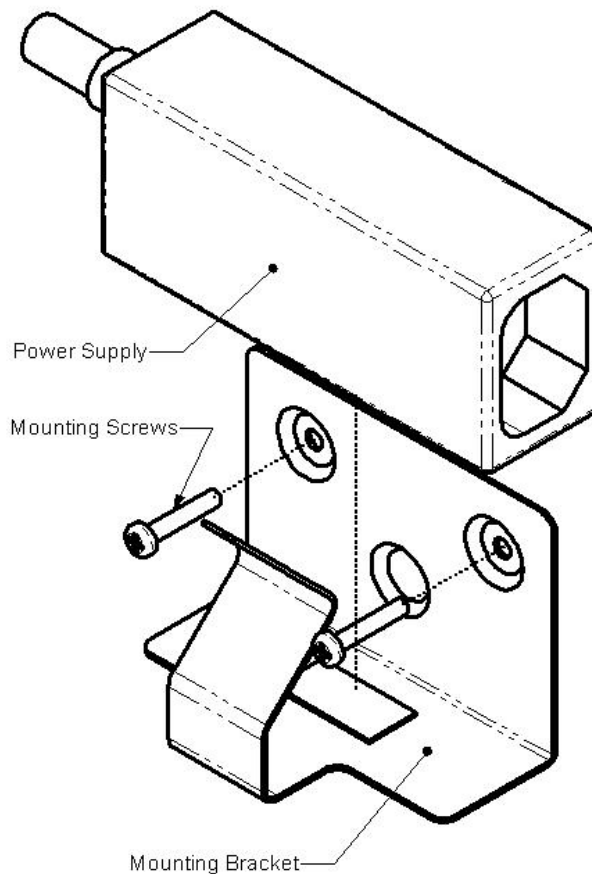

VALCOM LIMITED WARRANTY

Valcom, Inc. warrants its products only to the original purchaser, for its own use, to be free from defects in materials and workmanship under conditions of normal use and service for a period of one year from the date of shipment. This Limited Warranty obligation shall be limited to the replacement, repair or refund of any such defective device within the warranty period, provided that:

1. inspection by Valcom, Inc. indicates the validity of the claim;
2. the defect is not the result of damage, misuse or negligence after the original shipment;
3. the product has not been altered in any way or repaired by others and that factory sealed units are unopened (a service charge plus parts and labor will be applied to units defaced or physically damaged);
4. freight charges for the return of products to Valcom are prepaid;
5. all units 'out of warranty' are subject to a service charge. The service charge will cover minor repairs (major repairs will be subject to additional charges for parts and labor).

This Limited Warranty is in lieu of and excludes all other warranties, expressed or implied and in no event shall Valcom, Inc. be liable for any anticipated profits, consequential damages, loss of time or other losses incurred by the buyer in connection with the purchase, operation, maintenance, installation, removal or use of the product. The maximum liability of Valcom under this warranty is limited to the purchase price of the specific Product covered by the warranty.

Disclaimer. Except for the Limited Warranty provided herein, the product is provided "as-is" without any warranty of any kind whatsoever including, without limitation, any **WARRANTY OF MERCHANTABILITY, FITNESS FOR A PARTICULAR PURPOSE OR NON-INFRINGEMENT.**

This warranty specifically excludes damage incurred in shipment. In the event a product is received in damaged condition, the carrier should be notified immediately. Claims for such damage should be filed with the carrier involved in accordance with the F.O.B. point.

Headquarters:

Valcom, Inc.

5614 Hollins Road Roanoke, VA 24019-5056

Phone: (540) 563-2000 FAX: (540) 362-9800