

## VIP-432A-DF IP FLUSH MOUNT SPEAKER/CLOCK ASSEMBLY

### INTRODUCTION

The VIP-432A-DF IP Wall Speaker with Clock enables voice access and visual time indication to a single zone of paging over an IP-based LAN/WAN. This allows page zone extension anywhere on the network. The speaker level is adjusted via software during set up. Clock synchronization is initiated via connection to any Network Time Protocol (NTP) server accessible via the network. The enclosure is made of steel with a durable gray powder coated finish. The color of the enclosure can easily be changed to match any decor. A detachable black cloth grille is included. Power is provided to the VIP-432A-DF via a Power over Ethernet (PoE) switch meeting the 802.3af specification.

### SPECIFICATIONS

#### Access Methods

- PBX, FXO Port using a VIP-811
- POTS telephone set using a VIP-811
- PBX, FXS Port using a VIP-821
- Valcom M Cast Page Group
- SIP-enabled telephone system

#### Features

- RJ-45 network connection
- 802.3af compatible
- High Efficiency Class-D Amplifier
- Network Time Protocol (NTP) synchronization

### DIMENSIONS/WEIGHT

- 20.28" H x 14.38" W x 3.40" D  
(51.51cm x 36.53cm W x 8.64cm D)
- Weight: 4.25 LBS (1.91 kg)

### Environment



Temperature: 0 to +40° C  
Humidity: 0 to 85% non-precipitating



### Nominal Power Requirements

Via 802.3af PoE Ethernet Switch: Class 3



### Precautionary Designations

	<b>CAUTION</b> RISK OF ELECTRIC SHOCK DO NOT OPEN	
CAUTION: To reduce the risk of electric shock, Do not remove cover. No user serviceable parts inside. Refer servicing to qualified service personnel.		

	This symbol indicates that dangerous voltage constituting a risk of electric shock is present within this unit.
	This symbol indicates that there are important operating and maintenance instructions in the literature accompanying this unit.

### INSTALLATION

#### FCC Information

This equipment has been tested and found to comply with the limits for a Class A digital device, pursuant to Part 15 of the FCC Rules. These limits are designed to provide reasonable protection against harmful interference when the equipment is operated in a commercial environment. This equipment generates, uses and can radiate radio frequency energy and if not installed and used in accordance with the instruction manual, may cause harmful interference to radio communications. Operation of this equipment in a residential area may cause harmful interference in which case the user will be required to correct the interference at his own expense.

**IMPORTANT SAFETY INFORMATION**  
**CONSIGNES DE SÉCURITÉ IMPORTANTES**

1. Read these instructions.  
*Lisez ces instructions.*
2. Keep these instructions.  
*Conservez ces instructions.*
3. Read all warnings.  
*Respectez tous les avertissements.*
4. Follow all instructions.  
*Suivez toutes les instructions.*
5. Do not use this apparatus near water.  
*Ne pas utiliser cet appareil près de l'eau.*
6. Clean only with dry cloth.  
*Nettoyer avec un chiffon sec.*
7. Do not block any ventilation openings. Install in accordance with the manufacturer's instructions.  
*Ne pas bloquer les ouvertures de ventilation. Installer conformément aux instructions du fabricant.*
8. Do not install near any heat sources such as radiators, heat registers, stoves or other apparatus (including amplifiers) that produce heat.  
*Ne pas installer à proximité de sources de chaleur telles que radiateurs, registres de chaleur, poêles ou autres appareils (y compris les amplificateurs) produisant de la chaleur.*
9. Do not defeat the safety purpose of the polarized or grounding-type plug. A polarized plug has two blades with one wider than the other. A grounding type plug has two blades and a third grounding prong. The wide blade and the third prong are provided for your safety. If the provided plug does not fit into your outlet consult an electrician for replacement of the obsolete outlet.  
*Ne pas contourner le dispositif de sécurité de la fiche polarisée ou de mise à la terre. Une fiche polarisée possède deux lames dont une plus large que l'autre. Une fiche de terre a deux lames et une troisième broche de mise à la terre. La lame large et la troisième broche sont fournies pour votre sécurité. Si la fiche fournie ne rentre pas dans votre prise, veuillez consulter un électricien pour le remplacement de la prise obsolète.*
10. Protect the power cord from being walked on or pinched particularly at plugs, convenience receptacles and the point where they exit from the apparatus.  
*N'utilisez que des fixations / accessoires spécifiés par le fabricant.*
11. Only use attachments/accessories specified by the manufacturer.  
*N'utilisez que des fixations / accessoires spécifiés par le fabricant.*
12. Use only with the cart, stand, tripod, bracket or table specified by the manufacturer or sold with the apparatus. When a cart is used, use caution when moving the cart/apparatus combination to avoid injury from tip-over.  
*Utilisez uniquement avec le chariot, stand, trépied, support ou table spécifié par le fabricant ou vendu avec l'appareil. Quand un chariot est utilisé, Soyez prudent lorsque vous déplacez l'ensemble chariot / appareil pour éviter des blessures dues au renversement.*
13. Unplug this apparatus during lightning storms or when unused for a long period of time.  
*Débranchez cet appareil pendant les orages ou lorsqu'il n'est pas utilisé pendant une longue période de temps.*
14. Refer all servicing to qualified service personnel. Servicing is required when the apparatus has been damaged in any way. Such as when the power supply cord or plug is damaged, liquid has been spilled, objects have fallen into the apparatus or the apparatus has been exposed to rain or moisture and does not operate normally or has been dropped.  
*Confiez toute réparation à un personnel qualifié. Une réparation est nécessaire lorsque l'appareil a été endommagé de quelque façon. Par exemple lorsque le cordon d'alimentation ou la fiche est endommagé, du liquide a été renversé, si des objets sont tombés dans l'appareil ou le appareil a été exposé à la pluie ou à l'humidité et ne fonctionne pas normalement ou s'il est tombé.*



## Mounting

Valcom offers three backboxes (not included) for mounting the VIP-432A-DF speaker. The VB-R19 (recess mount); VB-S20 (surface mount) and VB-A21 (angled surface mount) are all designed to fit the VIP-432A-DF. Mount the backbox according to the instructions provided with the backbox. After mounting the backbox, connect the Ethernet cable to the RJ-45 jack on the speaker. Mount the speaker baffle to the backbox with the hardware provided.

## Assembly and Mounting

The VIP-432A-DF is designed for recessed or flush mounting to a Valcom backbox (not included). For recessed mounting, the Valcom VB-R19 may be used. For surface mounting, use the Valcom VB-S20 or VB-A21.

## Network Connection

The VIP-432A-DF has one RJ-45 network connector on the rear panel. Use a standard patch cable to connect the VIP-432A-DF to an Ethernet switch providing Power over Ethernet (PoE) meeting the 802.3af specification. If the switch does not provide power, a mid-span power injector may be used. (See Figure 1)

## Call Switch Connection

The VIP-432A-DF provides a call switch input via screw terminal connections, labeled Switch 1 and Ground.

## LED Connection

LED 1 (+) and LED 2 (-) is a current limited output designed to illuminate an optional LED. The LED is intended to provide visual indication of call progress. The LED illumination will flash when the call switch is pressed and will continue to flash until the call is answered. The LED illumination will be solid when a connection to the unit is established.

## -10 dB Line Level Out Connection

The -10dBm Line Level Out may be connected to up to 40 Valcom Self Amplified Speakers in order to provide additional sound reinforcement in an area.

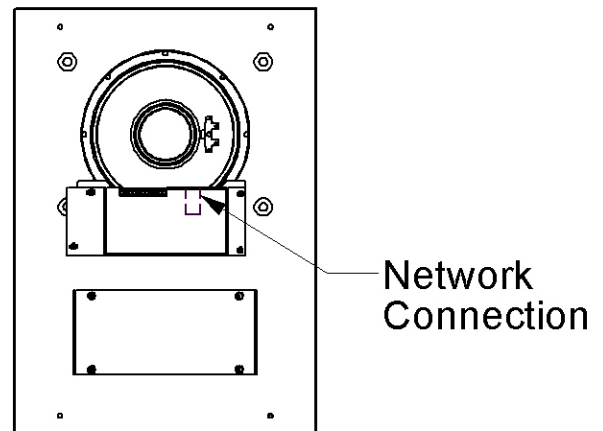
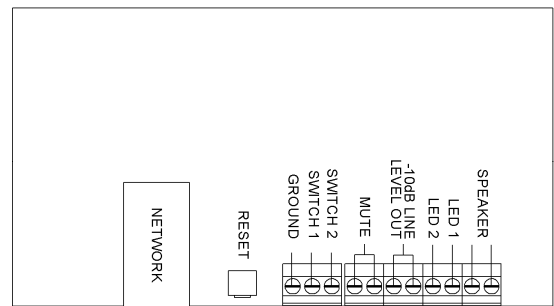

Figure 1. Connections

## Setup

Information specific to your application will need to be programmed to the VIP-432A-DF using a computer. The PC used for programming should be connected to the same subnet as VIP-432A-DF. Setup will be done using the IP Solutions Setup Tool. Download the latest version of the free IP Solutions Setup Tool from Valcom web site at [www.valcom.com/vipsetuptool](http://www.valcom.com/vipsetuptool).

## TECHNICAL ASSISTANCE

When trouble is reported, verify power is being supplied to the unit and there are no broken connections. If a spare unit is available, substitute a spare unit for the suspected defective unit.

Assistance in troubleshooting is available from the factory. Call (540) 563-2000 and press 1 for Technical Support or visit our website at <http://www.valcom.com>

Valcom equipment is not field repairable. Valcom, Inc. maintains service facilities in Roanoke, VA. Should repairs be necessary, attach a tag to the unit clearly stating your company name, address, phone number, contact person and the nature of the problem. Send the unit to

**Valcom, Inc.**  
**Repair & Return Dept.**  
**5614 Hollins Road**  
**Roanoke, Va. 24019-5056**

### VALCOM LIMITED WARRANTY

Valcom, Inc. warrants its products only to the original purchaser, for its own use, to be free from defects in materials and workmanship under conditions of normal use and service for a period of one year from the date of shipment. This Limited Warranty obligation shall be limited to the replacement, repair or refund of any such defective device within the warranty period, provided that:

1. inspection by Valcom, Inc. indicates the validity of the claim;
2. the defect is not the result of damage, misuse or negligence after the original shipment;
3. the product has not been altered in any way or repaired by others and that factory sealed units are unopened (a service charge plus parts and labor will be applied to units defaced or physically damaged);
4. freight charges for the return of products to Valcom are prepaid;
5. all units 'out of warranty' are subject to a service charge. The service charge will cover minor repairs (major repairs will be subject to additional charges for parts and labor).

**This Limited Warranty is in lieu of and excludes all other warranties, expressed or implied and in no event shall Valcom, Inc. be liable for any anticipated profits, consequential damages, loss of time or other losses incurred by the buyer in connection with the purchase, operation, maintenance, installation, removal or use of the product. The maximum liability of Valcom under this warranty is limited to the purchase price of the specific Product covered by the warranty.**

**Disclaimer.** Except for the Limited Warranty provided herein, the product is provided "as-is" without any warranty of any kind whatsoever including, without limitation, any **WARRANTY OF MERCHANTABILITY, FITNESS FOR A PARTICULAR PURPOSE OR NON-INFRINGEMENT.**

This warranty specifically excludes damage incurred in shipment. In the event a product is received in damaged condition, the carrier should be notified immediately. Claims for such damage should be filed with the carrier involved in accordance with the F.O.B. point.

Headquarters:  
Valcom, Inc.  
5614 Hollins Road Roanoke, VA 24019-5056  
Phone: (540) 563-2000 FAX: (540) 362-9800

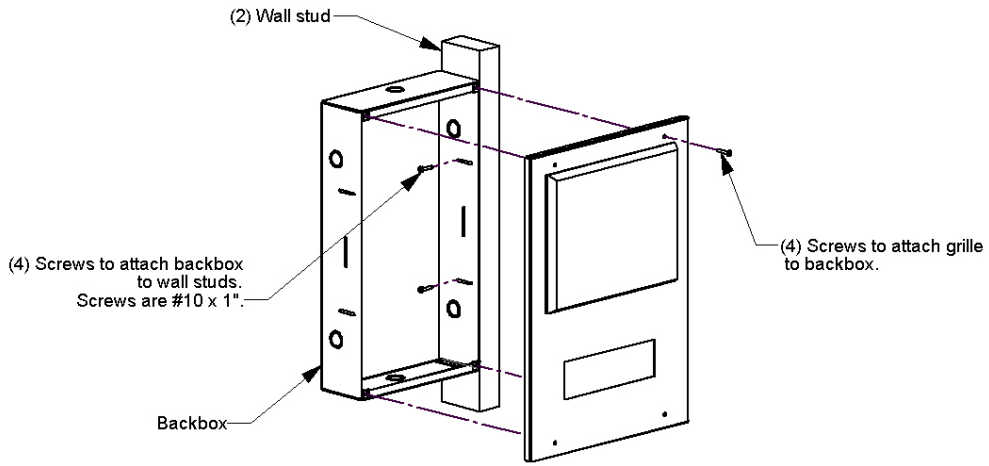

**VB-R19**

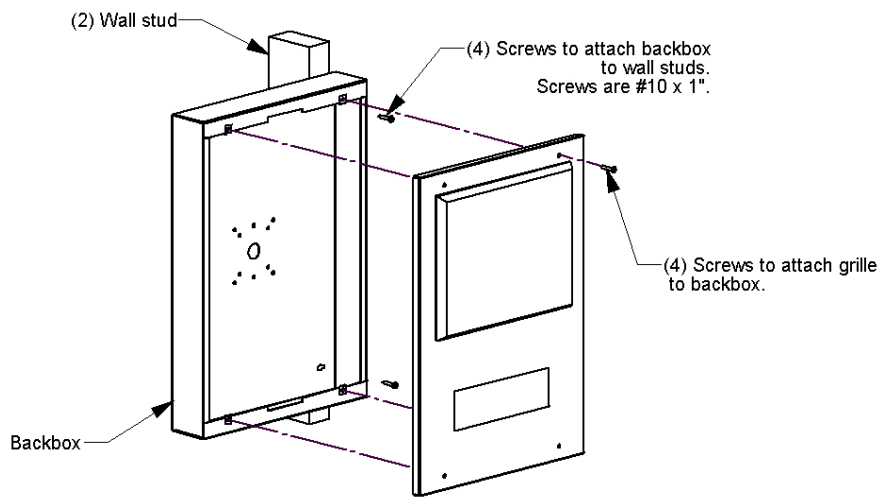

**VB-S20**

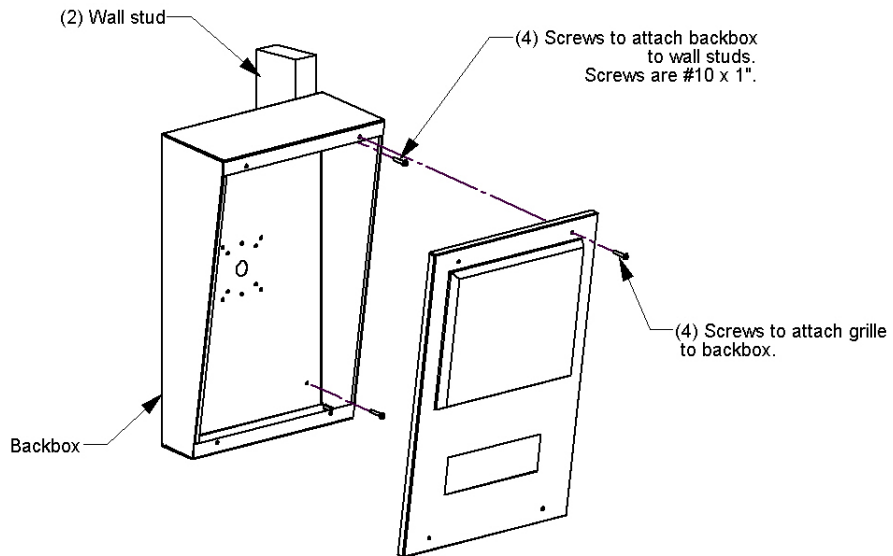

**VB-A21**