

## VIP-176A SIP Door Intercom

### INTRODUCTION

The VIP-176A SIP Talkback Door Intercom allows communication to SIP-based telephone systems or Valcom Enhanced Station Port adapters via an IP-based network.



### SPECIFICATIONS

#### Access Methods

- SIP – enabled telephone system
- PBX, FXO Port w/Valcom Enhanced Station Port
- POTS telephone set w/Valcom Enhanced Station Port
- Valcom M Cast Page Group

#### Features

- RJ-45 for network connection
- 1 Form C Smart Relay (optional)
- Network activity LEDs
- Power over Ethernet (PoE) 802.3af compatible

#### Dimensions/Weight:

- 4.88" H x 4.88" W x 2.5" D (including button)  
(12.4cm H x 12.4cm W x 6.4cm D)
- Weight: 0.82 lbs. (0.37 kg)

#### Nominal Power Requirements

Via 802.3af PoE Ethernet Switch: Class 3

#### Environment

##### Network Interface:

Temperature: 0 to +40° C

Humidity: 0 to 85% non-precipitating

- Suitable for indoor or outdoor installation, protected from direct precipitation.

### Precautionary Designations



### FCC Information

This equipment has been tested and found to comply with the limits for a Class A digital device, pursuant to Part 15 of the FCC Rules. These limits are designed to provide reasonable protection against harmful interference when the equipment is operated in a commercial environment. This equipment generates uses and can radiate radio frequency energy and if not installed and used in accordance with the instruction manual, may cause harmful interference to radio communications. Operation of this equipment in a residential area may cause harmful interference in which case the user will be required to correct the interference at his own expense.

# INSTALLATION

## Operation:

The VIP-176A provides door intercom access via network connections to customer telephone system or stand-alone telephone set. Interface to customer telephone system can be via SIP registration to a voice over IP (VoIP) telephone system, or FXO port (when used with a Valcom Enhanced Station Port). Pressing the call button on the door plate initiates a call to a user-specified telephone number and the call assurance LED on the door plate begins to flash. When the call is answered, a hands-free communications path is established to the door plate, and the call assurance LED on the door plate remains lit. An optional Smart Relay module, VM-SRLY is available separately, which provides one form C relay for uses such as activating door entry equipment.

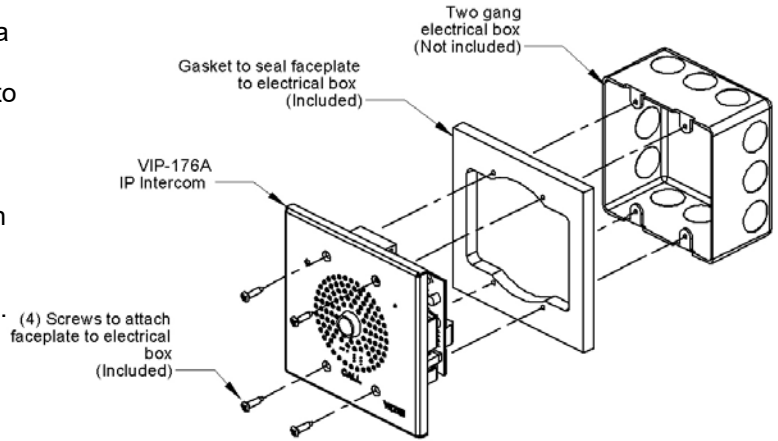

Figure 1.

## Mounting

**For enhanced protection against static electrical discharge, it is recommended the VIP-176A be installed into a grounded electrical box.**

The VIP-176A Doorplate is designed for double gang FD electrical box mounting. Verify depth of electrical box is adequate for mounting the VIP-176A. (See Figure 1)

When purchasing weatherproof box, the ground screw should be off-center. For example, Bell part number 5333-0 could be used. (See Figure 2)

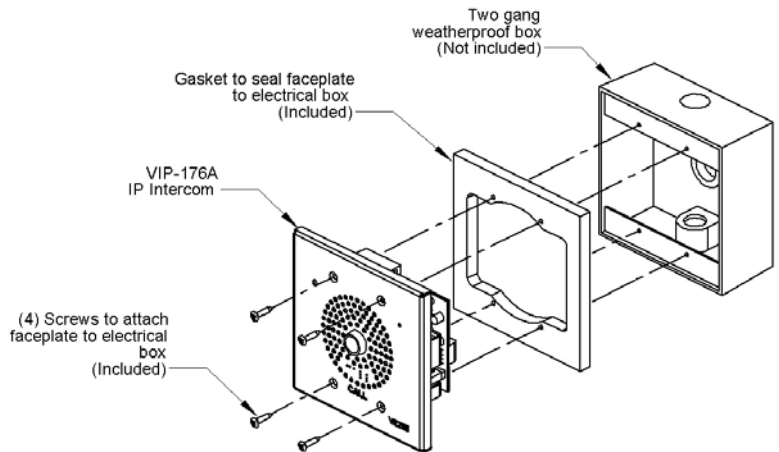

Figure 2.

## Power Connections

The only method of powering the VIP-176A is via a Power over Ethernet (PoE) switch or power injector meeting the 802.3af specification.

Make all required signal connections before connecting to Ethernet switch or power injector meeting the 802.3af specification.

## Network Connection

The VIP-176A has one RJ-45 Network connector. **Green LED:** (Link) Indicates Ethernet connection when illuminated.

**Yellow LED:** (Activity) Indicator flashes to indicate network activity.

Use a standard Ethernet patch cable to connect the NETWORK connector to an Ethernet switch. (See Figure 3).

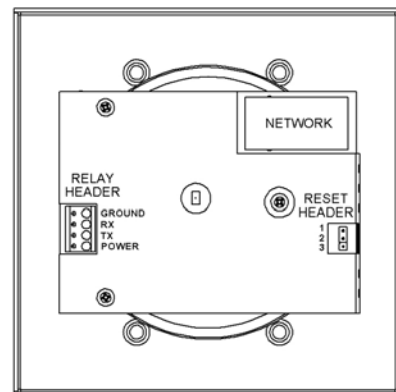

Figure 3.

### **Status Indicator Lights**

The VIP-176A Door plate is equipped with a status indicator LED. LED flashes when the call button is pressed and steady when the call is connected.

### **Relay Connections**

An optional Smart Relay module, VM-SRLY, may be ordered separately. Installation instructions to connect with the VIP-176A Relay Header are included with the VM-SRLY.

### **SETUP**

Information specific to your application will need to be programmed into the VIP-176A using a computer. The PC used for programming should be connected to the same subnet as the VIP-176A. Setup will be done using the IP Solution Setup Tool. Download the latest version of the free IP Solutions Setup Tool from the Valcom web site at [www.valcom.com/vipsetuptool](http://www.valcom.com/vipsetuptool)

### **TECHNICAL ASSISTANCE**

Assistance in troubleshooting is available from the factory. Call (540) 563-2000 and press 1 for Technical Support or via email at [support@valcom.com](mailto:support@valcom.com).

When requesting assistance, you should include all available information. General information and troubleshooting procedures are available on the Valcom website at [www.valcom.com](http://www.valcom.com). Valcom equipment is not field repairable. Valcom, Inc. maintains service facilities in Roanoke, VA.

Should repairs be necessary, attach a tag to the unit clearly stating your company name, address, phone number, contact person and the nature of the problem.

Send the unit to:

**Valcom, Inc.  
Repair & Return Dept.  
5614 Hollins Road  
Roanoke, Va. 24019-5056**

### **WARRANTY**

Warranty information may be found on our website at [www.valcom.com/warranty](http://www.valcom.com/warranty)