

VIP-480AL IP One-Way Horn

INTRODUCTION

The VIP-480AL IP One-way Horn provides for one-way communication when used in a Valcom VoIP based intercom/paging system.



SPECIFICATIONS

Access Methods

- PBX, FXO Port w/VIP-81X
- POTS telephone set w/VIP-81X
- FXS Port w/VIP-82X
- SIP telephone system

Features

- RJ-45 for network connection
- LED Status Indicator
- Network activity LEDs
- Power over Ethernet (PoE) 802.3af compatible

Dimensions/Weight

Horn –

- 6.80" H x 8.30" W x 3.30" D
(17.27 cm) x (21.08 cm) x (8.38 cm)
- Weight: 2.10 lbs. (0.95 kg)

Network Interface

- 1.62" H x 5.63" W x 3.45" D
(4.11 cm) x (14.30 cm) x (8.73 cm)
- **with brackets** – 8.22" W (20.87 cm)
- Weight: 2.10 lbs. (0.95 kg)

Nominal Power Requirements

Via 802.3af PoE Ethernet Switch: Class 3

Environment

Network Interface:

Temperature: 0 to +40° C
Humidity: 0 to 85% non-precipitating

Horn:



Suitable for indoor or outdoor installation

Packing List

Qty	Item
1	Network Interface
1	VIP-480AL Horn
1	VSP Document
1	VM-186 RJ-45 Connector
4	Wood Screws
1	"C" Clamp

Precautionary Designations

	CAUTION RISK OF ELECTRIC SHOCK DO NOT OPEN	
CAUTION: To reduce the risk of electric shock, Do not remove cover. No user serviceable parts inside. Refer servicing to qualified service personnel.		

	This symbol indicates that dangerous voltage constituting a risk of electric shock is present within this unit.
	This symbol indicates that there are important operating and maintenance instructions in the literature accompanying this unit.

FCC Information

This equipment has been tested and found to comply with the limits for a Class A digital device, pursuant to Part 15 of the FCC Rules. These limits are designed to provide reasonable protection against harmful interference when the equipment is operated in a commercial environment. This equipment generates, uses and can radiate radio frequency energy and if not installed and used in accordance with the instruction manual, may cause harmful interference to radio communications. Operation of this equipment in a residential area may cause harmful interference in which case the user will be required to correct the interference at his own expense.

INSTALLATION

Operation:

Provides one-way intercom via Network connection to customer telephone system or stand alone telephone set. Interface to customer telephone system can be via SIP registration, FXO port or FXS port (additional equipment required in all cases).

Mounting (Network Interface)

The Network Interface is designed for wall or table mounting and must be within 100 meters of the network switch.

Wall: Using the wood screws and mounting brackets provided, secure the Network Interface to the wall.

Mounting (Horn)

Flush Mount using Mounting Screws

The cardboard packing material in which the horn is shipped also serves as the template for flush mounting. Using the template, mark location of opening and mounting holes on wall. Drill holes appropriate to mounting hardware and cut out the opening. Make appropriate wiring connections and test the speaker for operation. Using appropriate mounting screws (not furnished) drill and mount the flange as shown.

UNIVERSAL BRACKET

Loosen or separate the universal bracket leaves by loosening or removing the handle and hardware. Using the back leaf as a template, mark the wall through the mounting holes. Drill and mount to the wall using appropriate screws (not furnished) or mount directly to a junction box. Mount the T-bracket to the back of the horn as shown using the (2) ½ inch screws provided.

"C" CLAMP FOR "I" BEAM MOUNTING

A "C" clamp is provided with the horns to allow mounting to a beam. Place the bolt through the hole in the bottom of the base to secure the "C" clamp to the beam. It is suggested that the horn be mounted to the underside of the "I" beam to provide maximum positioning adjustments. Mount "C" clamp with (2) ½ inch screws provided.

Power Connections

The only method of powering the Network Interface is via a Power over Ethernet (PoE) switch or power injector meeting the 802.3af specification. Make all required signal connections before connecting to Ethernet switch or power injector meeting the 802.3af specification.

Network Connection

The Network Interface has one RJ-45 network connector and one RJ-45 horn connector. Use standard Ethernet patch cable to connect the NETWORK connector of the Network Interface to a PoE Ethernet switch.

Signal Connections

Audio output connection is made from the Signal Output. The RJ-45 connector on the horn is connected directly to the RJ-45 Signal Output socket on the IP Link. See Figure 1.

If additional length is required, any standard T568B extension may be used. See Figure 2.

Status Indicator Lights

The VIP-480AL has 2 status indication lights on the front panel:

Green LED: (Link) Indicates Ethernet connection when illuminated.

Yellow LED: (Activity) Indicator flashes to indicate network activity.

Setup

Information specific to your application will need to be programmed into the VIP-480AL using a computer. The PC used for programming should be connected to the same subnet as the VIP-480AL. Setup will be done using the VIP-102B IP Solutions Setup Tool. Download the latest version of the free IP Solutions Setup Tool from the Valcom web site at www.valcom.com/vipsetuptool.

TECHNICAL ASSISTANCE

Assistance in troubleshooting is available from the factory. Call (540) 563-2000 and press 1 for Technical Support or visit our website at <http://www.valcom.com>.

Valcom equipment is not field repairable. Valcom, Inc. maintains service facilities in Roanoke, VA. Should repairs be necessary, attach a tag to the unit clearly stating your company name, address, phone number, contact person and the nature of the problem. Send the unit to:

**Valcom, Inc.
Repair & Return Dept.
5614 Hollins Road
Roanoke, Va. 24019-5056**

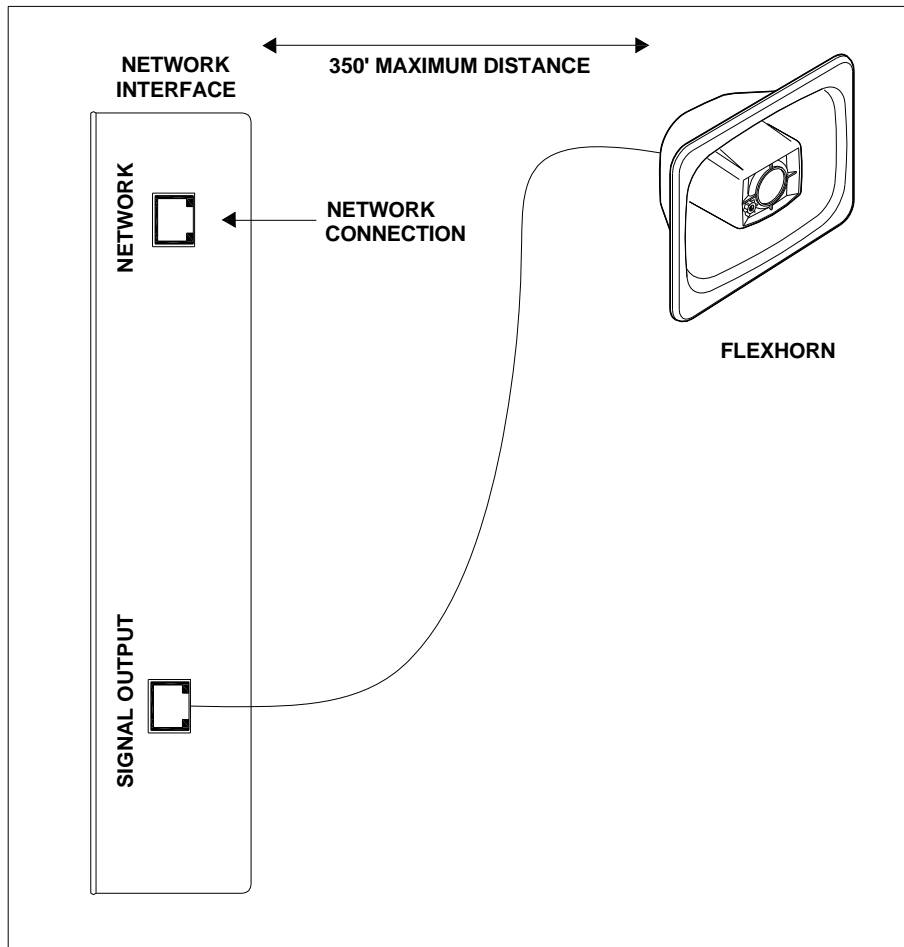

Figure 1

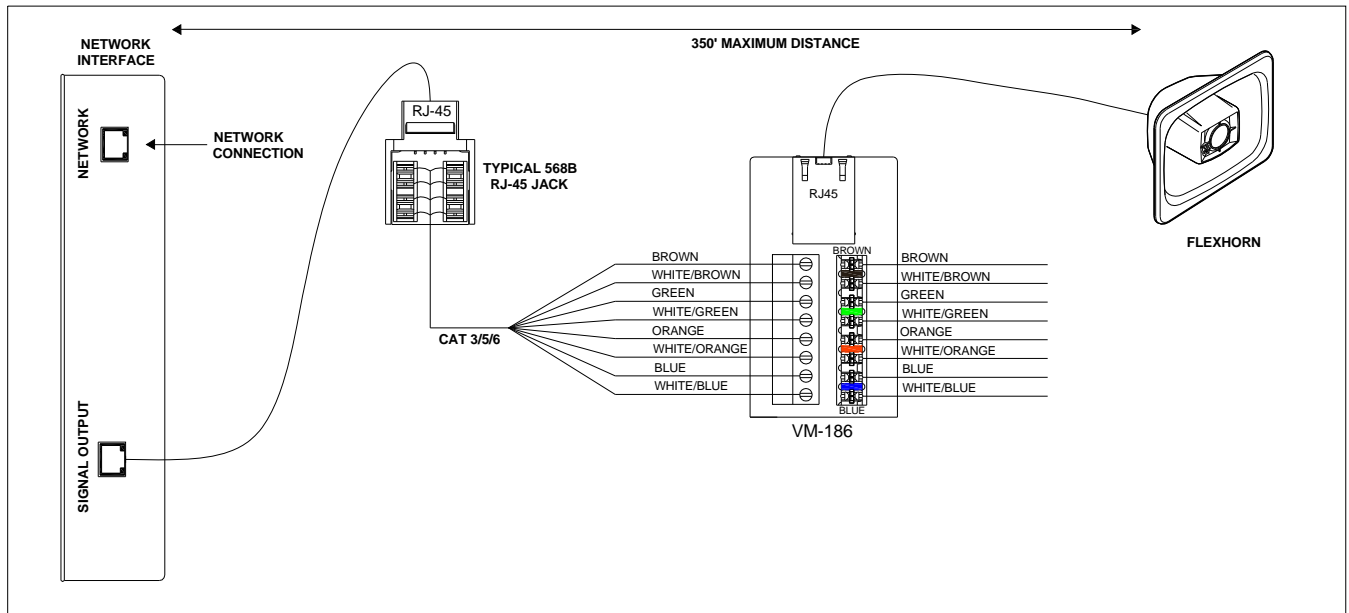

Figure 2

VALCOM LIMITED WARRANTY

Valcom, Inc. warrants its products only to the original purchaser, for its own use, to be free from defects in materials and workmanship under conditions of normal use and service for a period of one year from the date of shipment. This Limited Warranty obligation shall be limited to the replacement, repair or refund of any such defective device within the warranty period, provided that:

1. inspection by Valcom, Inc. indicates the validity of the claim;
2. the defect is not the result of damage, misuse or negligence after the original shipment;
3. the product has not been altered in any way or repaired by others and that factory sealed units are unopened (a service charge plus parts and labor will be applied to units defaced or physically damaged);
4. freight charges for the return of products to Valcom are prepaid;
5. all units 'out of warranty' are subject to a service charge. The service charge will cover minor repairs (major repairs will be subject to additional charges for parts and labor).

This Limited Warranty is in lieu of and excludes all other warranties, expressed or implied and in no event shall Valcom, Inc. be liable for any anticipated profits, consequential damages, loss of time or other losses incurred by the buyer in connection with the purchase, operation, maintenance, installation, removal or use of the product. The maximum liability of Valcom under this warranty is limited to the purchase price of the specific Product covered by the warranty.

Disclaimer. Except for the Limited Warranty provided herein, the product is provided "as-is" without any warranty of any kind whatsoever including, without limitation, any **WARRANTY OF MERCHANTABILITY, FITNESS FOR A PARTICULAR PURPOSE OR NON-INFRINGEMENT.**

This warranty specifically excludes damage incurred in shipment. In the event a product is received in damaged condition, the carrier should be notified immediately. Claims for such damage should be filed with the carrier involved in accordance with the F.O.B. point.

Headquarters:

Valcom, Inc.

5614 Hollins Road Roanoke, VA 24019-5056

Phone: (540) 563-2000 FAX: (540) 362-9800

UNIVERSAL BRACKET

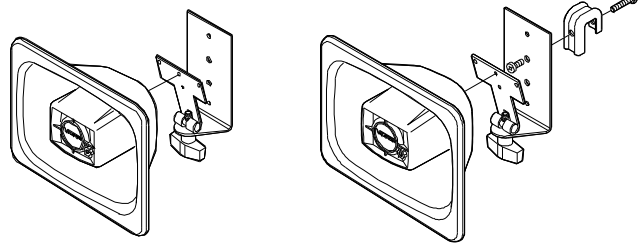

SURFACE MOUNTED WITH A UNIVERSAL MOUNTING BRACKET

UNIVERSAL BRACKET WITH CLAMP

"C" CLAMP FOR "I" BEAM MOUNTING

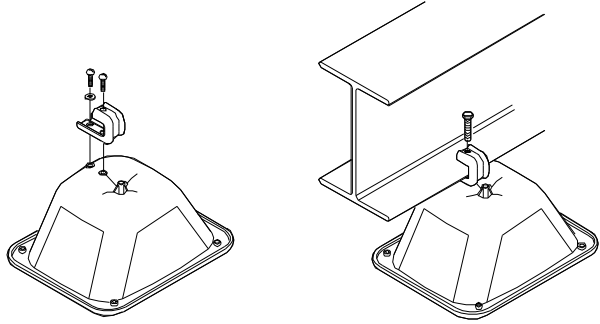

ATTACH CLAMP TO HORN

ATTACH FLEXHORN TO BEAM

FLUSH MOUNT USING MOUNTING SCREWS:

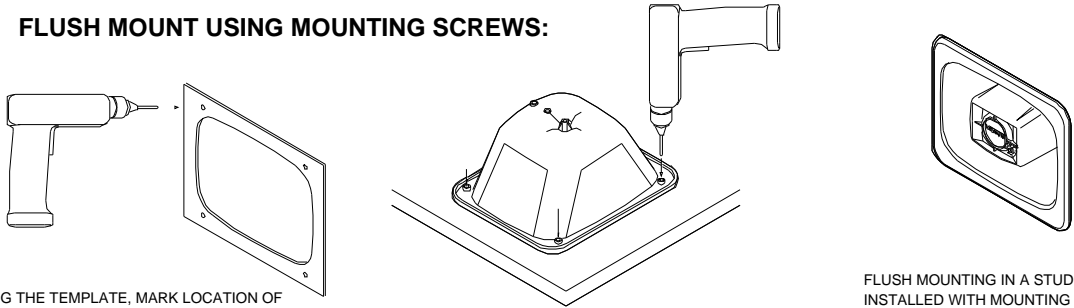

USING THE TEMPLATE, MARK LOCATION OF OPENING AND MOUNTING HOLES ON WALL. DRILL HOLES APPROPRIATE TO MOUNTING HARDWARE AND CUT OUT THE OPENING.

HOLDING FLEXHORN FIRMLY AGAINST A FLAT SURFACE, DRILL THROUGH EACH MOUNTING BOSS AS SHOWN.

FLUSH MOUNTING IN A STUD WALL INSTALLED WITH MOUNTING SCREWS OR CONSTRUCTION CEMENT.

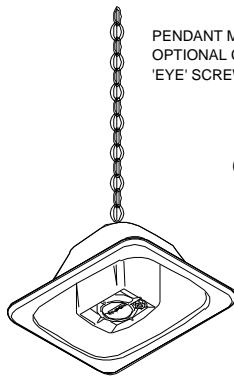

PENDANT MOUNTING WITH OPTIONAL CHAIN AND 'EYE' SCREW

OTHER MOUNTING OPTIONS:

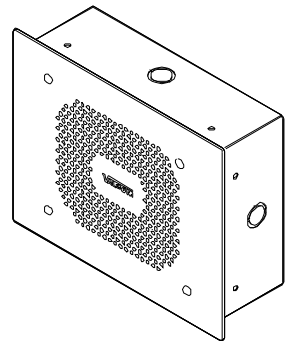

OPTIONAL V-9805 VANDAL RESISTANT ENCLOSURE