

VIP-814B QUAD NETWORK STATION PORT

INTRODUCTION

The VIP-814B Quad Network Station Port allows most loop start terminal devices to be connected to a managed IP-based LAN/WAN.

SPECIFICATIONS

Access Methods

- PBX, FXO Port
- POTS telephone set

Features

- RJ-45 for network connection
- 4 RJ-11 telephone connections
- 4 Relays with Form C contacts
- Generates Caller ID Signals
- Front panel Status/Link/Activity LEDs
- 2 RENS
- 2.5mm jack for external power (optional)
- Power over Ethernet (PoE) 802.3af compatible

Dimensions/Weight

- 1.72 H x 7.00" W x 11.875" D
(4.36cm H x 17.78cm W x 30.16cm D)
- Weight: 2.11 lbs. (0.95 kg)

Nominal Specifications

Input Impedance:	600 Ohms
Input Level:	-10dBm
Output Impedance:	600 Ohms
Output Level:	- 10dBm nominal
Relay Current:	1 AMP @ 24VDC

Nominal Power Requirements

Via rear panel barrel connector:

Voltage:	24VDC
Current:	325mA

Via 802.3af (PoE) Ethernet Switch:

802.3af:	Class 3
----------	---------



Environment

Temperature:	0 to +40° C
Humidity:	0 to 85% non-precipitating

WARNING:

To Reduce The Risk Of Fire Or Electric Shock Do Not Expose This Apparatus To Rain Or Moisture.

AVERTISSEMENT : Afin de réduire les risques d'incendie ou de décharge électrique, évitez d'exposer le système à la pluie ou à l'humidité.

INSTALLATION

NOTE: The telephone system referred to in this manual is the customer premise equipment such as an electronic key system, a PBX or a dedicated single line telephone sets. The VIP-814B is not intended for direct or indirect connection to the public telephone network. When used with a customer premise telephone system such as a key system or PBX system, these units are interfaced to the system via a fully protected system central office port, which is a fully protected interface device. Also, the host system must be configured to disallow central office trunk conferencing in order to prevent indirect connection to the public network.

Precautionary Designations

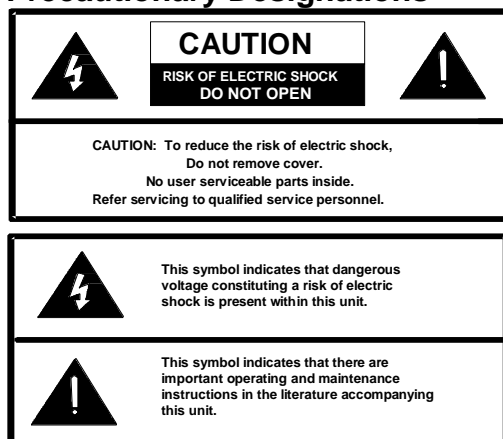

FCC Information

This equipment has been tested and found to comply with the limits for a Class A digital device, pursuant to Part 15 of the FCC Rules. These limits are designed to provide reasonable protection against harmful interference when the equipment is operated in a commercial environment. This equipment generates, uses and can radiate radio frequency energy and if not installed and used in accordance with the instruction manual, may cause harmful interference to radio communications. Operation of this equipment in a residential area may cause harmful interference in which case the user will be required to correct the interference at his own expense.

Mounting

The VIP-814B is designed for wall, table or two units rack mounting together.

Table: Provided with the VIP-814B are four rubber pads. Peel pads from their carrier backing and place at the four corners of the bottom of the unit.

Wall: Using #8 screws (included), attach the wall mounting brackets to each side of the VIP-814B as shown in Figure 1. Use the included wood screws to attach the VIP-814B to the wall. For surfaces other than wood, use hardware appropriate for the surface (not provided).

Rack: Two VIP-814B units may be joined together and installed into a 1U rack slot. Using Figure 2 as a guide, attach the interlock brackets and end mounting brackets to each of the VIP-814B units, then mount the combined units into an available rack slot.

Power Connections

The preferred method of powering a VIP-814B is via a Power over Ethernet (PoE) switch meeting the 802.3af specification.

If the rear panel barrel connector is used for power, the preferred power supply is a Valcom VIP-324D.

Make all required signal connections before applying power to the unit. If powering via 802.3af, make sure all signal connections via the back panel are made then connect the VIP-814B to the Ethernet switch.

If power is supplied via the barrel connector, make sure all signal connections are secure. Attach the unit to the network via the front panel RJ-45 Ethernet connector. Apply power by plugging the power supply in to the VIP-814B via the barrel connector on the rear of the VIP-814B.

Network Connection

The VIP-814B has one RJ-45 network connector on the front panel.

Use a standard Ethernet patch cable to connect the VIP-814B to an Ethernet switch. If the Ethernet switch is 802.3af compliant, the VIP-814B will draw power from it.

Signal Connections

On the back panel, the VIP-814B has 4 RJ-11 jacks for telephone connection and 2 terminal blocks for relay connections.

FXO Connections: Connect loop start FXO port or standard analog telephones to the VIP-814B via the rear panel RJ-11 jacks labeled Phone 1, Phone 2, Phone 3 and Phone 4. Tip and Ring appear on pins 3 and 4 of these jacks.

Relay Connections: Access to the four form C relays is provided via two six pin screw terminal blocks. The relays are labeled K1, K2, K3 and K4. Each relay is brought out on three terminals. The common contact (COM) is the middle terminal with the normally closed (N.C.) contact on the right and the normally open (N.O.) contact on the left. Relay contacts are rated for 1A @ 24VDC.

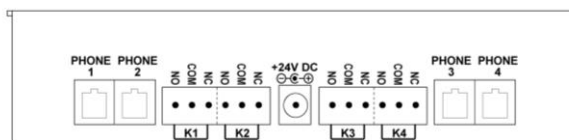

Rear View

Setup

Information specific to your application will need to be programmed into the VIP-814B using a computer. The PC used for programming should be connected to the same subnet as the VIP-814B.

Setup will be done using the IP Solutions Setup Tool. Download the latest version of the free IP Solutions Setup Tool from Valcom web site at www.valcom.com/vipsetuptool.

Status Indicator Lights

The VIP-814B has 3 status indication lights on the front panel:

STATUS: Illuminates at regular intervals during normal operation. On steady indicates unit is in reset mode.

The network jack provides two LED indicators:

Green LED: (Link) Indicates Ethernet connection when illuminated.

Yellow LED: (Activity) Indicator flashes to indicate network activity.

TECHNICAL ASSISTANCE

When trouble is reported, verify power is being supplied to the unit and there are no broken connections. If a spare unit is available, substitute a spare unit for the suspected defective unit.

Assistance in troubleshooting is available from the factory. Call (540) 563-2000 and press 1 for Technical Support or via email at support@valcom.com.

When requesting assistance, you should include all available information. General information and troubleshooting procedures are available on the Valcom website at www.valcom.com.

Valcom equipment is not field repairable. Valcom, Inc. maintains service facilities in Roanoke, VA. Should repairs be necessary, attach a tag to the unit clearly stating your company name, address, phone number, contact person and the nature of the problem. Send the unit to:

**Valcom, Inc.
Repair & Return Dept.
5614 Hollins Road
Roanoke, Va. 24019-5056**

VALCOM LIMITED WARRANTY

Valcom, Inc. warrants its products only to the original purchaser, for its own use, to be free from defects in materials and workmanship under conditions of normal use and service for a period of one year from the date of shipment. This Limited Warranty obligation shall be limited to the replacement, repair or refund of any such defective device within the warranty period, provided that:

1. inspection by Valcom, Inc. indicates the validity of the claim;
2. the defect is not the result of damage, misuse or negligence after the original shipment;
3. the product has not been altered in any way or repaired by others and that factory sealed units are unopened (a service charge plus parts and labor will be applied to units defaced or physically damaged);
4. freight charges for the return of products to Valcom are prepaid;
5. all units 'out of warranty' are subject to a service charge. The service charge will cover minor repairs (major repairs will be subject to additional charges for parts and labor).

This Limited Warranty is in lieu of and excludes all other warranties, expressed or implied and in no event shall Valcom, Inc. be liable for any anticipated profits, consequential damages, loss of time or other losses incurred by the buyer in connection with the purchase, operation, maintenance, installation, removal or use of the product. The maximum liability of Valcom under this warranty is limited to the purchase price of the specific Product covered by the warranty.

Disclaimer. Except for the Limited Warranty provided herein, the product is provided "as-is" without any warranty of any kind whatsoever including, without limitation, any **WARRANTY OF MERCHANTABILITY, FITNESS FOR A PARTICULAR PURPOSE OR NON-INFRINGEMENT.**

This warranty specifically excludes damage incurred in shipment. In the event a product is received in damaged condition, the carrier should be notified immediately. Claims for such damage should be filed with the carrier involved in accordance with the F.O.B. point.

Headquarters:

Valcom, Inc.

5614 Hollins Road Roanoke, VA 24019-5056

Phone: (540) 563-2000 FAX: (540) 362-9800

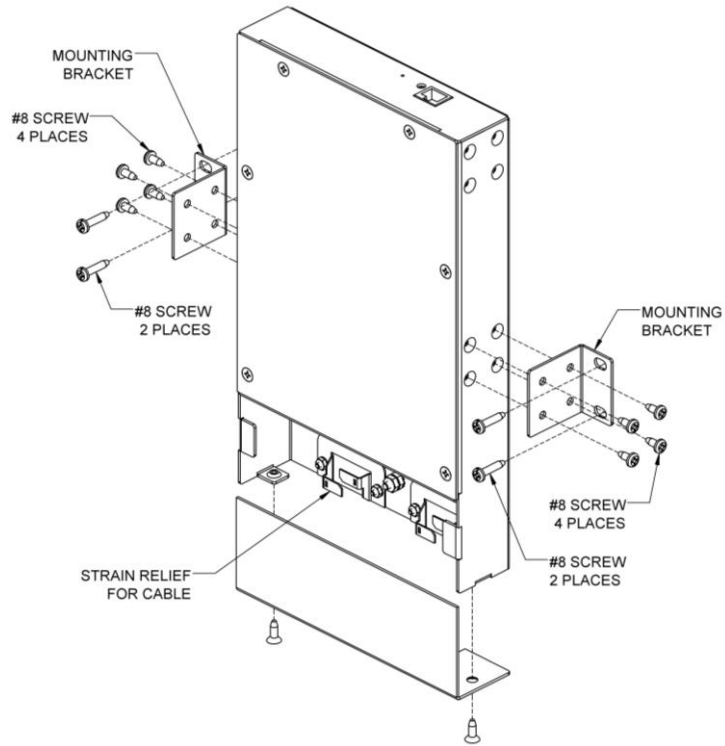

Figure 1. Wall Mount

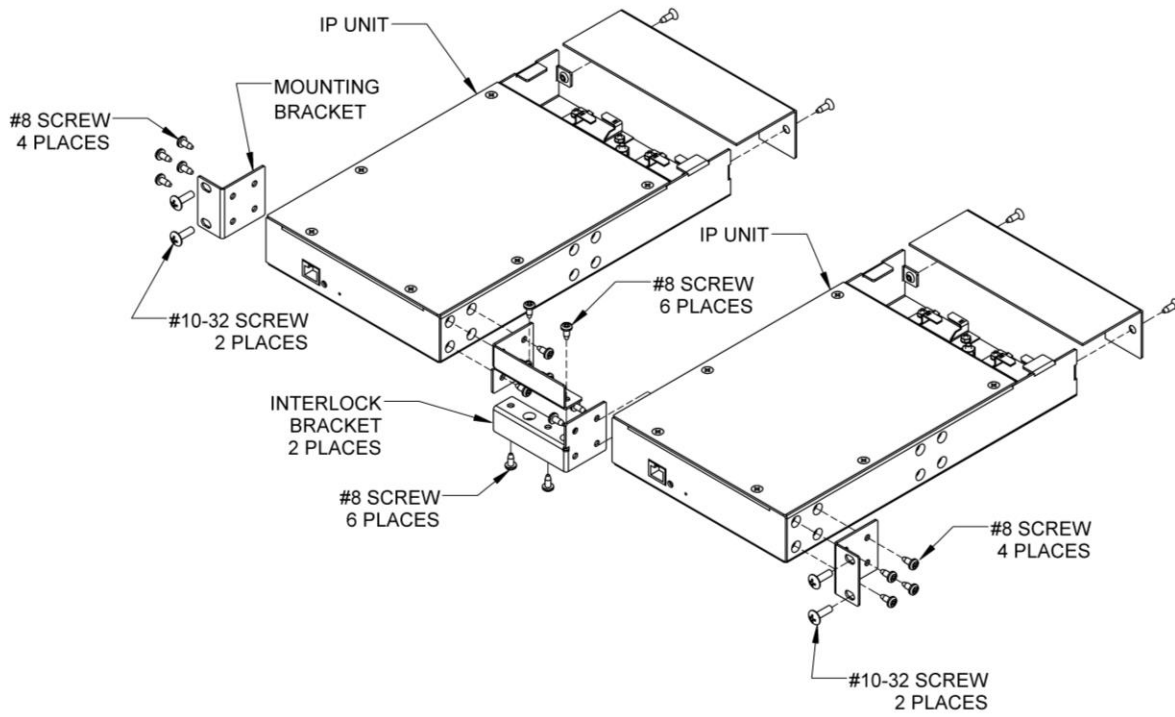

Figure 2. Rack Mount