

VIP-148L IP Talkback Horn

INTRODUCTION

The VIP-148L IP Talkback Horn enables two-way handsfree voice access to a single location over an IP-based network. This allows a page zone extension anywhere on the network. The horn audio level is electronically adjusted via software. A call switch input connection is provided for call initiation, and a line level Auxiliary Input allows connection to a local audio source. Power is provided to the VIP-148L via a Power over Ethernet (PoE) switch meeting the 802.3af specification.



SPECIFICATIONS

Access Methods

- PBX, FXO Port w/VIP-811
- POTS telephone set w/VIP-811
- FXS Port w/VIP-821
- SIP telephone system

Features

- RJ-45 for network connection
- LED Status Indicator
- Network activity LEDs
- Power over Ethernet (PoE) 802.3af compatible
- Aux input for background music

Dimensions/Weight VIP-148L

- Horn - 7.38" H x 10.0" W x 10.4" D (18.75cm x 25.4cm x 26.42cm)
- Network Interface – 9.13" H x 4.5" W x 1.5" D (23.19cm x 11.43cm x 3.81cm)
- Weight: 5.60 lbs. (2.54 kg)

Nominal Power Requirements

Via 802.3af (PoE) Ethernet Switch: Class 3

Environment

VIP-148L Network Interface:

Temperature: 0 to +40° C

Humidity: 0 to 85% non-precipitating



VIP-148L Horn:



Suitable for indoor or outdoor installation

Packing List

Qty	Item
1	VIP-148L Network Interface
1	VIP-148L Horn
1	VSP Document
4	Wood Screws
4	Rubber Pads
1	"C" Clamp
1	VM-186 RJ-45 Connector

Precautionary Designations

	CAUTION RISK OF ELECTRIC SHOCK DO NOT OPEN	
<p>CAUTION: To reduce the risk of electric shock, Do not remove cover. No user serviceable parts inside. Refer servicing to qualified service personnel.</p>		

	<p>This symbol indicates that dangerous voltage constituting a risk of electric shock is present within this unit.</p>
	<p>This symbol indicates that there are important operating and maintenance instructions in the literature accompanying this unit.</p>

FCC Information

This equipment has been tested and found to comply with the limits for a Class A digital device, pursuant to Part 15 of the FCC Rules. These limits are designed to provide reasonable protection against harmful interference when the equipment is operated in a commercial environment. This equipment generates, uses and can radiate radio frequency energy and if not installed and used in accordance with the instruction manual, may cause harmful interference to radio communications. Operation of this equipment in a residential area may cause harmful interference in which case the user will be required to correct the interference at his own expense.

INSTALLATION

Operation:

Provides talkback intercom via Network connection to customer telephone system or stand alone telephone set. Interface to customer telephone system can be via SIP registration, FXO port or FXS port (additional equipment required in all cases). The optional call button may be programmed to initiate a call to one of the above telephone system interfaces. When the call is answered, a hands-free communications path is established to the horn.

Mounting (Network Interface)

The VIP-148L Network Interface is designed for wall or table mounting and must be within 100 meters of the network switch.

Mounting (Horn)

The VIP-148L Horn is designed for most FD electrical box or wall mounting and must be within 300 meters of the VIP-148L Network Interface. See NEMA OS 3-2002 sec.1.2.3.5 for FD box specifications.

Attaching Speaker to Base

NOTE: For ease of installation, the base can be attached to the speaker before or after the base is mounted.

- Loosen position adjustment knob
- Insert the ball of the base into the socket of the speaker
- Tighten the position adjustment knob

These horns should be mounted 15 to 20 feet above the floor to allow for best sound distribution. The units can be mounted to a wall, a beam or an electrical box.

- Mount the base to a wall using the two holes

provided. Knockout holes are provided for punch out should additional holes be desired.

- A "C" clamp is provided with the horns to allow mounting to a beam. Place the bolt through the hole in the bottom of the base to secure the "C" clamp to the beam (See Figure 1). It is suggested that the horn be mounted to the underside of the "I" beam to provide maximum positioning adjustments.
- Connection to an electrical backbox is accomplished by channeling wire through the ball of the base and making appropriate connections. The base has holes punched for a double-gang square box, but by punching out additional knockout holes, the base can be mounted to a single-gang or octagon box (See Figure 2).

The horns may be rotated or moved up and down to obtain the desired position by loosening the position adjustment knob (See Figures 1 and 2) at the bottom of the unit approximately one turn. and re- Make required adjustments tighten knob.

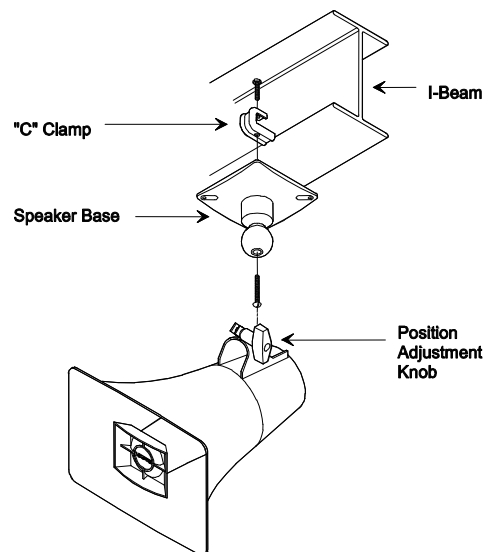

Figure 1 - Mounting to a Beam with a "C" Clamp

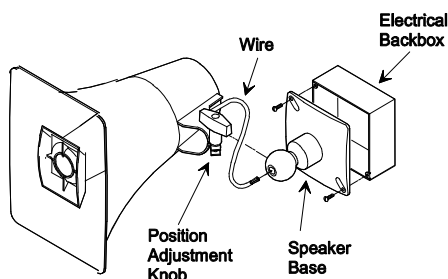

Figure 2 - Mounting to an Electrical Backbox

Network Interface:

Table: Provided with the VIP-148L Network Interface are four rubber stick on pads. Peel pads off their carrier backing and place at the four corners of the bottom of the unit.

Wall: Using the wood screws provided, secure the VIP-148L Network Interface to the wall.

Power Connections

The only method of powering a VIP-148L Network Interface is via a Power over Ethernet (PoE) switch or power injector meeting the 802.3af specification. Make all required signal connections before connecting to Ethernet switch or power injector meeting the 802.3af specification.

Network Connection

The VIP-148L Network Interface has one RJ-45 Ethernet network connector and one RJ-45 horn connector.

Use a standard Ethernet patch cables to connect the VIP-148L to an Ethernet switch.

Signal Connections

Connect RJ-45 patch cable using EIA/TIA 568A or 568B Standard to the horn connector of the VIP-148L Network Interface, then connect to VM-186 RJ-45 connector. Connect the Brown and White/Brown pair to the horn.

If desired, a normally-open call button may be connected to the Blue, White/Blue pair of the horn RJ-45 connector. The VM-186 RJ-45 connector provides easy access these connections.

Aux input

Aux input on the VIP-148L Network Interface accepts line level audio such as background music and broadcasts it through the horn. During announcements, the aux input is muted and remains muted until the call is terminated.

Status Indicator Lights

The VIP-148L Network Interface has 3 status indication lights on the side panel:

STATUS: Flashes during normal operation, and solid when unit in reset.

LINK: Indicates 100 Mbit Ethernet connection when illuminated. No activity indicates 10 Mbit connection.

ACT: Indicator flashes to indicate network activity.

Setup

Information specific to your application will need to be programmed into the VIP-148L using a computer. The PC used for programming should be connected to the same subnet as the VIP-148L. Setup will be done using the IP Solutions Setup Tool. The IP Solutions Setup Tool is available for download on the Valcom website at www.valcom.com/vipsetuptools.

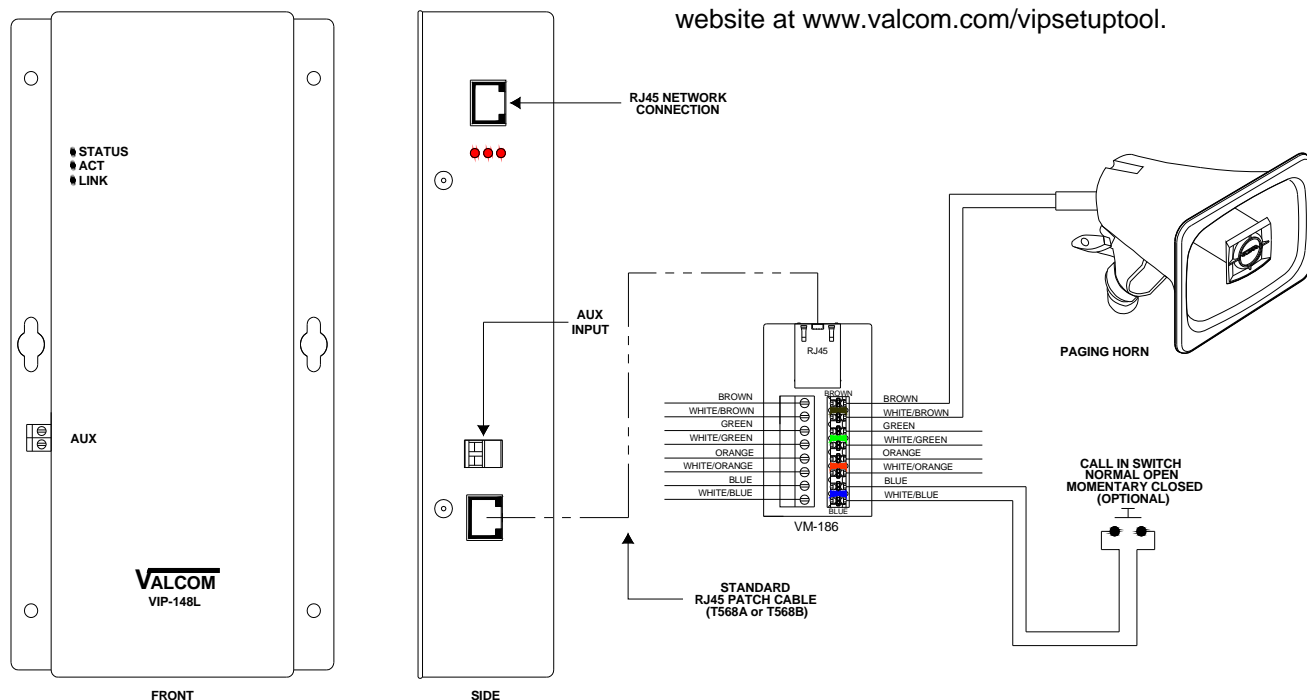

TECHNICAL ASSISTANCE

Assistance in troubleshooting is available from the factory when problems are encountered. Call (540) 563-2000 and press 1 for Technical Support or visit our website at <http://www.valcom.com>.

Valcom equipment is not field repairable. Valcom, Inc. maintains service facilities in Roanoke, VA.

Should repairs be necessary, attach a tag to the unit clearly stating your company name, address, phone number, contact person and the nature of the problem. Send the unit to:

**Valcom, Inc.
Repair & Return Dept.
5614 Hollins Road
Roanoke, Va. 24019-5056**

VALCOM LIMITED WARRANTY

Valcom, Inc. warrants its products only to the original purchaser, for its own use, to be free from defects in materials and workmanship under conditions of normal use and service for a period of one year from the date of shipment. This Limited Warranty obligation shall be limited to the replacement, repair or refund of any such defective device within the warranty period, provided that:

1. inspection by Valcom, Inc. indicates the validity of the claim;
2. the defect is not the result of damage, misuse or negligence after the original shipment;
3. the product has not been altered in any way or repaired by others and that factory sealed units are unopened (a service charge plus parts and labor will be applied to units defaced or physically damaged);
4. freight charges for the return of products to Valcom are prepaid;
5. all units 'out of warranty' are subject to a service charge. The service charge will cover minor repairs (major repairs will be subject to additional charges for parts and labor).

This Limited Warranty is in lieu of and excludes all other warranties, expressed or implied and in no event shall Valcom, Inc. be liable for any anticipated profits, consequential damages, loss of time or other losses incurred by the buyer in connection with the purchase, operation, maintenance, installation, removal or use of the product. The maximum liability of Valcom under this warranty is limited to the purchase price of the specific Product covered by the warranty.

Disclaimer. Except for the Limited Warranty provided herein, the product is provided "as-is" without any warranty of any kind whatsoever including, without limitation, any **WARRANTY OF MERCHANTABILITY, FITNESS FOR A PARTICULAR PURPOSE OR NON-INFRINGEMENT.**

This warranty specifically excludes damage incurred in shipment. In the event a product is received in damaged condition, the carrier should be notified immediately. Claims for such damage should be filed with the carrier involved in accordance with the F.O.B. point.

Headquarters:

Valcom, Inc.

5614 Hollins Road Roanoke, VA 24019-5056

Phone: (540) 563-2000 FAX: (540) 362-9800