

VIP-848A Networked Input & Relay Module

INTRODUCTION

The VIP-848A Networked Input & Relay Module allows passing of contact closures, which are software programmable to be either Form A or Form B, over an IP-based LAN/WAN. Multiple VIP-848A Networked Input & Relay Modules can be used on the same network to create very large and distributed systems.



SPECIFICATIONS

Features

- 8 Relay Contacts That Are Programmable To Form A or Form B
- 8 Contact Closure Inputs
- RJ-45 For Network Connection
- Front Panel Activity LED
- Removable Connector Provided For Input And Relay Interface
- 2.5mm Jack For DC Power
- Power Over Ethernet (PoE) 802.3af Compliant
- No Server Required
- 1 to 11 Digit Dial Plans
- Easy Windows Based Setup

Dimensions/Weight

- 1.50" H x 6.19" W x 5.88" D
(3.81cm H x 15.72cm W x 14.94cm D)
- Weight: 1.00 lbs. (0.45 kg)

Nominal Specifications

Input Impedance: 10k Ohms
Relay Current: 1 AMP @ 24VDC

Nominal Power Requirements

Via Back Panel Barrel Connector:

Voltage: 24VDC
Current: 325mA

Via 802.3af PoE Ethernet Switch:

802.3af: Class 3

Environment

Temperature: +32 to +104°F (0 to +40°C)
Humidity: 0 to 85% Non-Precipitating

Packing List

Qty	Item
1	VIP-848A
1	VSP Document
2	Mounting Brackets
4	Rubber Pads

INSTALLATION

FCC Information

This equipment has been tested and found to comply with the limits for a Class A digital device, pursuant to Part 15 of the FCC Rules. These limits are designed to provide reasonable protection against harmful interference when the equipment is operated in a commercial environment. This equipment generates, uses and can radiate radio frequency energy and if not installed and used in accordance with the instruction manual, may cause harmful interference to radio communications. Operation of this equipment in a residential area may cause harmful interference in which case the user will be required to correct the interference at his own expense.

Precautionary Designations

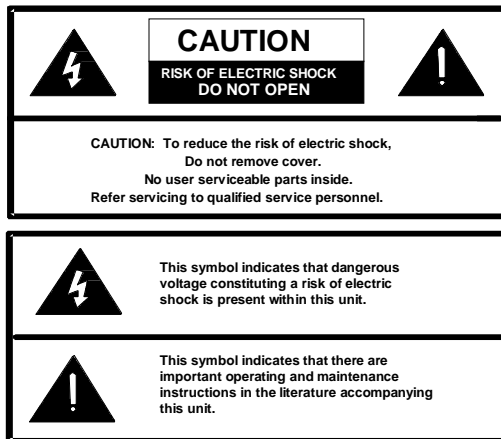

Mounting

The VIP-848A is designed for wall or table mounting.

Table: Provided with the VIP-848A are four rubber stick on pads. Peel these pads off their carrier backing and place at the four corners of the bottom of the unit.

Wall: Using the bracket and hardware provided, secure the VIP-848A to the wall.

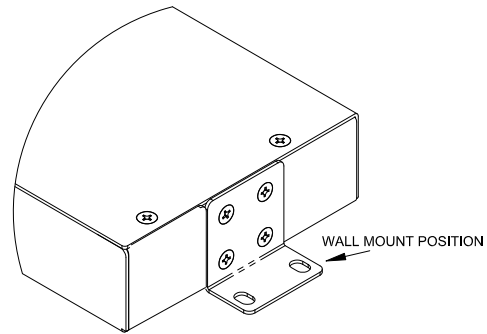

Power Connections

The preferred method of powering a VIP-848A is via a Power over Ethernet (PoE) switch meeting the 802.3af specification.

If the rear panel barrel connector is used for power, the preferred power supply is a Valcom VIP-324D.

Make all required signal connections before applying power to the unit. If powering via 802.3af, make sure all signal connections via the rear panel are made then connect the VIP-848A to the Ethernet switch.

If power is provided via the barrel connector, make sure all signal connections are secure. Attach the unit to the network via the front panel RJ-45 Ethernet connector. Apply power by plugging the power supply in to the VIP-848A via the barrel connector on the rear of the VIP-848A.

Network Connection

The VIP-848A has one RJ-45 network connector on the front panel.

Use a standard Ethernet patch cable to connect the VIP-848A to an Ethernet switch. If the Ethernet switch is 802.3af compliant the VIP-848A will draw power from it.

Signal Connections

The VIP-848A has 16 signal connectors on the rear panel:

- 8 Contact Closure Inputs
- 8 Relay Contacts that are programmable as Form A or Form B

Status Indicator Lights

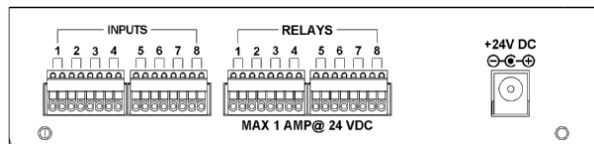

Rear View

STATUS: Flashes to indicate power.

LINK: Indicates 100 Mbit Ethernet connection when illuminated. No activity indicates 10 Mbit connection.

ACT: Indicator flashes to indicate network activity.

SETUP:

Information specific to your application will need to be programmed into the VIP-848A using a computer. The PC used for programming should be connected to the same subnet as the VIP-848A.

Setup will be done using the IP Solutions Setup Tool. Download the latest version of the free IP Solutions Setup Tool from the Valcom web site at www.valcom.com/vipsetuptools.

TECHNICAL ASSISTANCE

When trouble is reported, verify power is being supplied to the unit and there are no broken connections. If a spare unit is available, substitute a spare unit for the suspected defective unit.

Assistance in troubleshooting is available from the factory. Call (540) 563-2000 and press 1 for Technical Support or via email at support@valcom.com.

When requesting assistance, you should include all available information. It is strongly suggested that you go to the web site and review the information at www.valcom.com.

Valcom equipment is not field repairable. Valcom, Inc. maintains service facilities in Roanoke, VA. Should repairs be necessary, attach a tag to the unit clearly stating your company name, address, phone number, contact person and the nature of the problem. Send the unit to:

Valcom, Inc.
Repair & Return Dept.
5614 Hollins Road
Roanoke, Va. 24019-5056

VALCOM LIMITED WARRANTY

Valcom, Inc. warrants its products only to the original purchaser, for its own use, to be free from defects in materials and workmanship under conditions of normal use and service for a period of one year from the date of shipment. This Limited Warranty obligation shall be limited to the replacement, repair or refund of any such defective device within the warranty period, provided that:

1. inspection by Valcom, Inc. indicates the validity of the claim;
2. the defect is not the result of damage, misuse or negligence after the original shipment;
3. the product has not been altered in any way or repaired by others and that factory sealed units are unopened (a service charge plus parts and labor will be applied to units defaced or physically damaged);
4. freight charges for the return of products to Valcom are prepaid;
5. all units 'out of warranty' are subject to a service charge. The service charge will cover minor repairs (major repairs will be subject to additional charges for parts and labor).

This Limited Warranty is in lieu of and excludes all other warranties, expressed or implied and in no event shall Valcom, Inc. be liable for any anticipated profits, consequential damages, loss of time or other losses incurred by the buyer in connection with the purchase, operation, maintenance, installation, removal or use of the product. The maximum liability of Valcom under this warranty is limited to the purchase price of the specific Product covered by the warranty.

Disclaimer. Except for the Limited Warranty provided herein, the product is provided "as-is" without any warranty of any kind whatsoever including, without limitation, any **WARRANTY OF MERCHANTABILITY, FITNESS FOR A PARTICULAR PURPOSE OR NON-INFRINGEMENT.**

This warranty specifically excludes damage incurred in shipment. In the event a product is received in damaged condition, the carrier should be notified immediately. Claims for such damage should be filed with the carrier involved in accordance with the F.O.B. point.

Headquarters:

Valcom, Inc.

5614 Hollins Road Roanoke, VA 24019-5056

Phone: (540) 563-2000 FAX: (540) 362-9800