

# V-1040

## INSTALLATION INSTRUCTIONS FOR CLEAN ROOM CEILING SPEAKER

The Valcom Ceiling Speaker, V-1040 is a self-amplified and capable of reproducing voice paging in clean room environments. The V-1040 has a screwdriver adjustable volume control located on the 1 Watt amplifier circuit board. The V-1040 has an 8-inch speaker. The speaker requires -24VDC, 50mA (1-power unit). The speaker features the following, large rubber o-ring to seal the grille to the ceiling, rubber washers for all mounting hardware and a polycarbonate dust shield located between the speaker and the grille.

### Dimensions/Weight

- V-1040                                      13.00" Dia. x 3.00"D                      (33.02cm Dia. x 7.62cm D)                      2.5 lbs. (1.13kg)

### Coverage

The area covered by a ceiling speaker is determined by the height of the ceiling. If ceiling height is 8 feet, the speaker will cover 256 sq. ft. With a ceiling height of 10 feet, the speaker will cover 400 sq. ft. If the ceiling is 20 feet high, the speaker will cover 1600 sq. ft.

### Connections

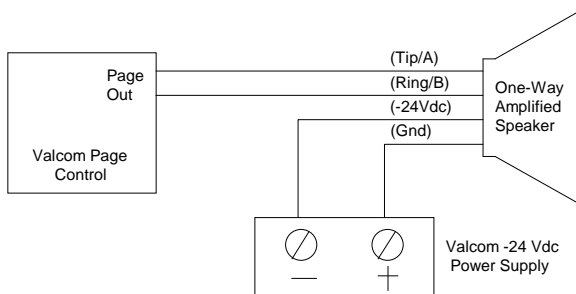

Refer to Figure 1 for audio and electrical connections. Category 3 24 AWG structured cable may be used for all connections.

**NOTE: Do not connect this speaker directly to a 25/70/100 Volt amplifier as damage to both the amplifier and speaker may occur. A V-1095 may be used to allow the use of Valcom self-amplified speakers on 70V speaker lines.**

**FIGURE 1: TYPICAL CONNECTIONS**

### Installation

#### Suspended Ceiling Installation

After determining the speaker location and referring to Figure 2 cut an 8.5" diameter hole in the ceiling tile. Attach the backbox to the bridge with the four screws provided and position the assembly on the back of the ceiling tile. **Before continuing speaker installation using a small screwdriver set Volume Control to 2/3 rotation.** Place the large rubber O-ring on the back of the speaker assembly and using the four screws equipped with washers and O-rings mount the speaker assembly to the bridge/backbox assembly. Do not over-tighten the speaker mounting screws. Hand tighten only. For a proper seal the large O-ring should compress slightly. It is not necessary for the edge of the metal grille to touch the ceiling tile for a proper seal. Refer to Figure 2.

**FIGURE 2: V-1040 INSTALLATION INSTRUCTIONS**

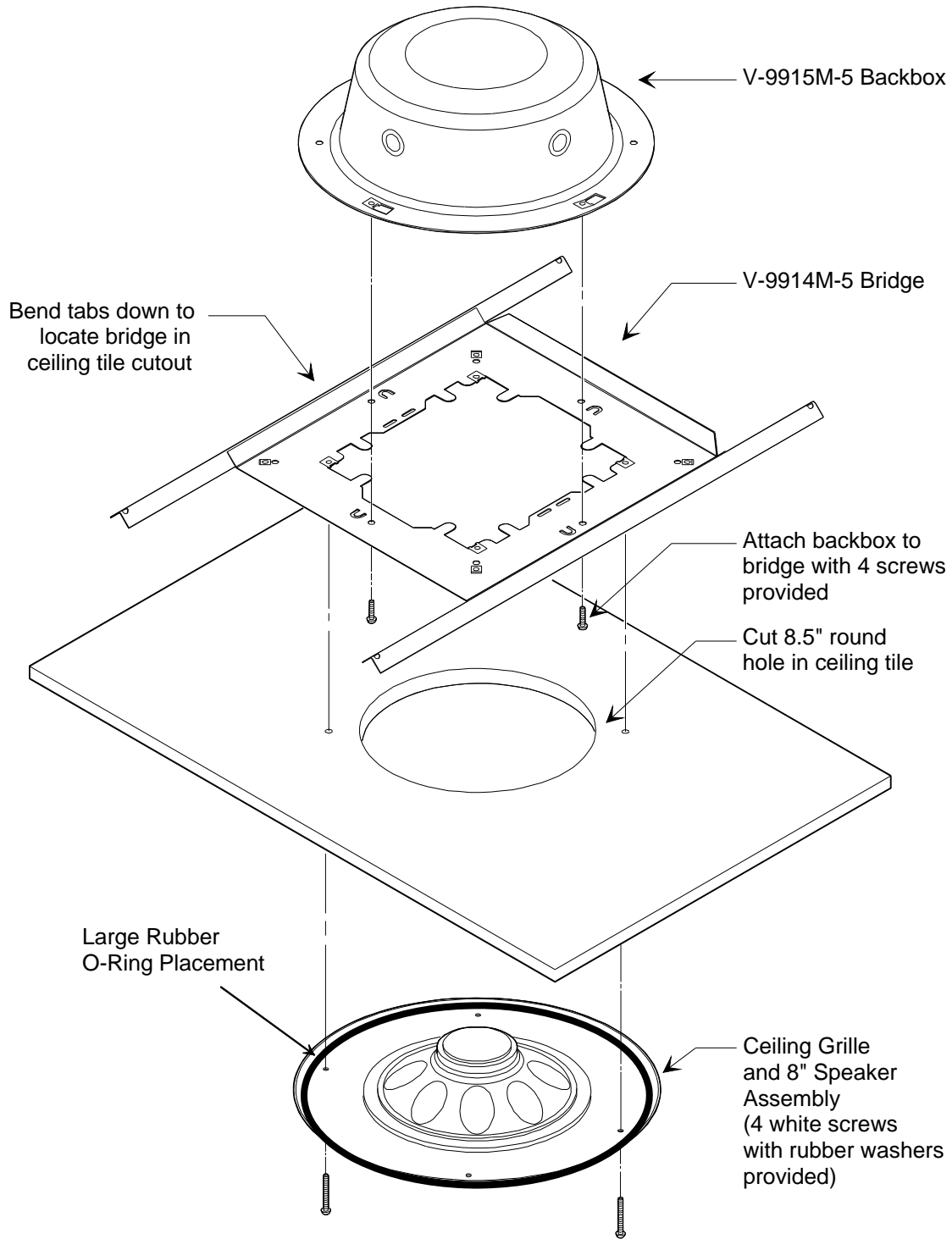

### Solid Surface Ceiling (Sheetrock)

In a sheetrock ceiling installation it is necessary to install the preconstruction ring and backbox assembly before the installation of the sheetrock. Referring to Figure 3 mount the backbox to the speaker mounting ring and attach the assembly to the ceiling joists using the appropriate hardware. Cut a 12 1/8" diameter hole in the in the sheetrock to provide clearance for the speaker mounting ring and backbox assembly.

**Before continuing speaker installation using a small screwdriver set Volume Control to 2/3 rotation.** Place the large rubber O-ring on the back of the speaker assembly and using the four screws equipped with washers and O-rings mount the speaker assembly to the speaker ring/backbox assembly. Do not over-tighten the speaker mounting screws. Hand tighten only. For a proper seal the large O-ring should compress slightly. It is not necessary for the edge of the metal grille to touch the ceiling for a proper seal. Refer to Figure 3.

FIGURE 3: V-1040 INSTALLATION INSTRUCTIONS HARD CEILING

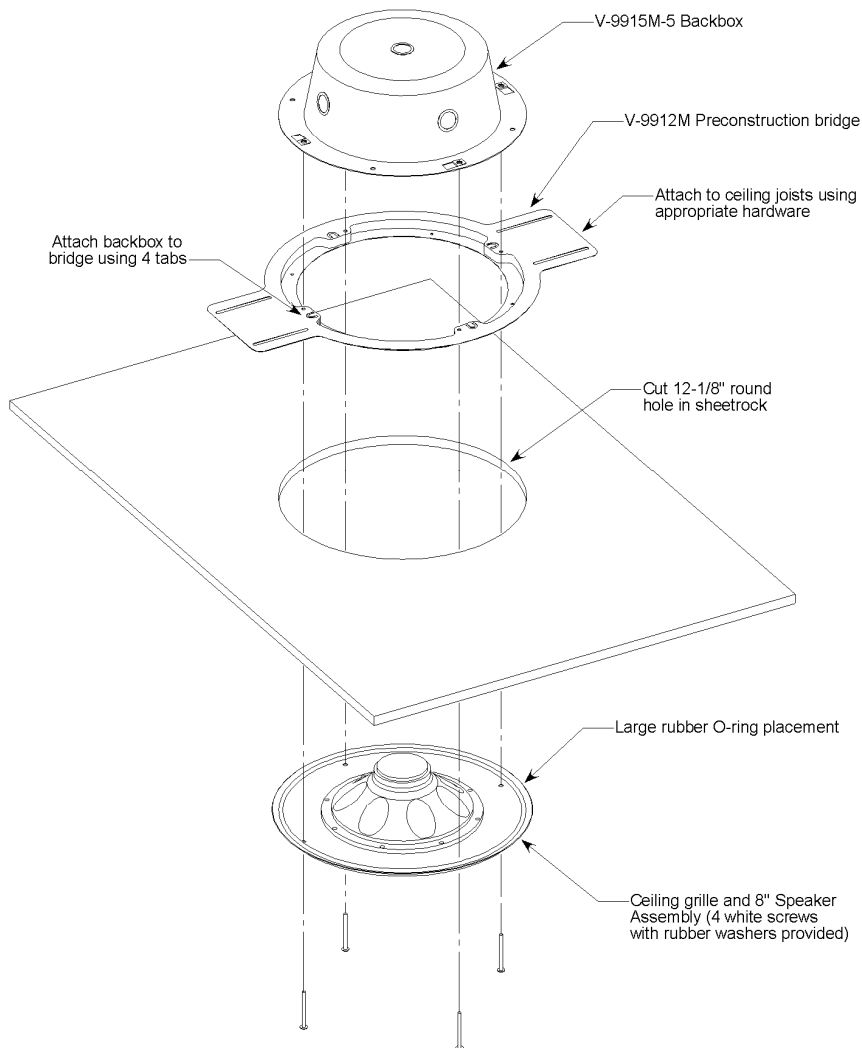

## TECHNICAL ASSISTANCE

When trouble is reported, verify there are no broken connections. Assistance in troubleshooting is available from the factory. Call (540) 563-2000 and press 1 for Technical Support, or visit our website at <http://www.valcom.com>.

Valcom equipment is not field repairable. Valcom, Inc. maintains service facilities in Roanoke, VA. Should repairs be necessary, attach a tag to the unit clearly stating company name, address, phone number, contact person and nature of the problem. Send the unit to:

**Valcom, Inc.**  
**Repair & Return Dept.**  
**5614 Hollins Road**  
**Roanoke, VA 24019-5056**

<b>TROUBLESHOOTING CHART</b>	
<b>SYMPTOMS</b>	<b>ACTIONS</b>
1. No audio from speaker	1a. Check that volume control is turned up (Clockwise). 1b. Using a lineman's test set, check for the proper audio level on the Tip and Ring leads and if necessary also at the source.
2. Low volume from speaker	2a. Check that volume control is turned up. 2b. Check voltage at the speaker assembly when in use, -18 to -24VDC required. 2c. Using a lineman's test set, check for the proper audio level on Tip and Ring leads. It is possible that some low-level audio will be heard with only one side of Tip and Ring connected.
3. Loud squeal (Feedback)	3a. Turn down (Counter-clockwise) volume of the speaker. 3b. Increase the distance between the telephone and speaker. 3c. Install a noise canceling handset on the telephone in severe problem areas. 3d. Add a V-9962, Digital Feedback Eliminator.

### VALCOM LIMITED WARRANTY

Valcom, Inc. warrants its products to be free from defects in materials and workmanship under conditions of normal use and service for a period of one year from the date of shipment. The obligation under this warranty shall be limited to the replacement, repair or refund of any such defective device within the warranty period, provided that:

1. inspection by Valcom, Inc. indicates the validity of the claim;
2. the defect is not the result of damage, misuse or negligence after the original shipment;
3. the product has not been altered in any way or repaired by others and that factory sealed units are unopened (a service charge plus parts and labor will be applied to units defaced or physically damaged);
4. freight charges for the return of products to Valcom are prepaid;
5. all units 'out of warranty' are subject to a service charge. The service charge will cover minor repairs (major repairs will be subject to additional charges for parts and labor).

**This warranty is in lieu of and excludes all other warranties, expressed or implied, and in no event shall Valcom, Inc. be liable for any anticipated profits, consequential damages, loss of time or other losses incurred by the buyer in connection with the purchase, operation or use of the product.**

This warranty specifically excludes damage incurred in shipment. In the event a product is received in damaged condition, the carrier should be notified immediately. Claims for such damage should be filed with the carrier involved in accordance with the F.O.B. point.

Headquarters:  
 Valcom, Inc.  
 5614 Hollins Road  
 Roanoke, VA 24019-5056  
 Phone: (540) 563-2000  
 FAX: (540) 362-9800