

TECHNICAL ASSISTANCE

When trouble is reported, verify there are no broken connections to the unit. Assistance in troubleshooting is available from the factory. When calling, you should have a VOM and a lineman's test set available and be calling from the job site. Call (540) 563-2000 and press 1 for Technical Support, or visit our website at <http://www.valcom.com>.

Valcom equipment is not field repairable. Valcom, Inc. maintains service facilities in Roanoke, VA. Should repairs be necessary, attach a tag to the unit clearly stating your company name, address, phone number, contact person, and the nature of the problem. Send the unit to:

Valcom, Inc.
Repair and Return Dept.
5614 Hollins Road
Roanoke, VA 24019-5056

VALCOM LIMITED WARRANTY

Valcom, Inc. warrants its products only to the original purchaser, for its own use, to be free from defects in materials and workmanship under conditions of normal use and service for a period of one year from the date of shipment. This Limited Warranty obligation shall be limited to the replacement, repair or refund of any such defective device within the warranty period, provided that:

1. inspection by Valcom, Inc. indicates the validity of the claim;
2. the defect is not the result of damage, misuse or negligence after the original shipment;
3. the product has not been altered in any way or repaired by others and that factory sealed units are unopened (a service charge plus parts and labor will be applied to units defaced or physically damaged);
4. freight charges for the return of products to Valcom are prepaid;
5. all units 'out of warranty' are subject to a service charge. The service charge will cover minor repair (major repairs will be subject to additional charges for parts and labor).

This Limited Warranty is in lieu of and excludes all other warranties, expressed or implied and in no event shall Valcom, Inc. be liable for any anticipated profits, consequential damages, loss of time or other losses incurred by the buyer in connection with the purchase, operation, maintenance, installation, removal or use of the product. The maximum liability of Valcom under this warranty is limited to the purchase price of the specific Product covered by the warranty.

Disclaimer. Except for the Limited Warranty provided herein, the product is provided "as-is" without any warranty of any kind whatsoever including, without limitation, any **WARRANTY OF MERCHANTABILITY, FITNESS FOR A PARTICULAR PURPOSE OR NON-INFRINGEMENT.**

This warranty specifically excludes damage incurred in shipment. In the event a product is received in damaged condition, the carrier should be notified immediately. Claims for such damage should be filed with the carrier involved in accordance with the F.O.B. point.

Headquarters:
 Valcom, Inc.
 5614 Hollins Road Roanoke, VA 24019-5056
 Phone: (540) 563-2000 FAX: (540) 362-9800

INSTALLATION INSTRUCTIONS FOR



V-1096 Audio Interface

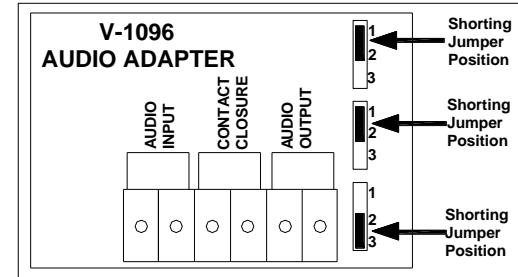

DIMENSIONS/WEIGHT

- 1.75" H x 3.75" W x 1.25" D (4.45cm H x 9.53cm W x 3.2cm D)
- 0.5 lbs. (0.23 kg)

CONNECTIONS

The V-1096 is used to connect the V-9908 Message/Page Panel to Valcom one-way amplified speakers and horns. In addition it is used to connect the Message/Page panel to various Valcom page controls.

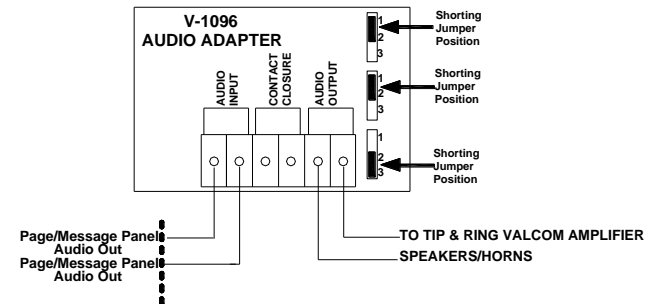

FIGURE 1: Connections to Valcom One-Way Amplified Speakers and Horns

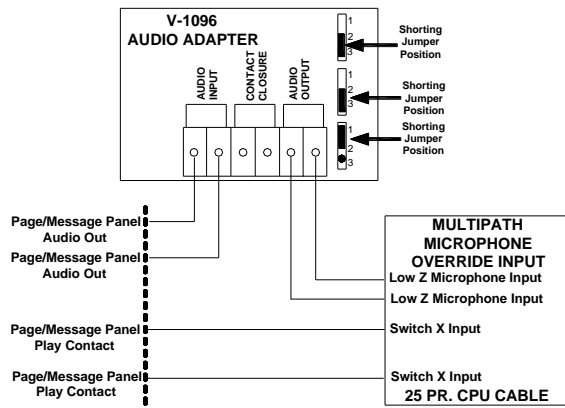

Figure 2: Connections to MultiPath Microphone Input

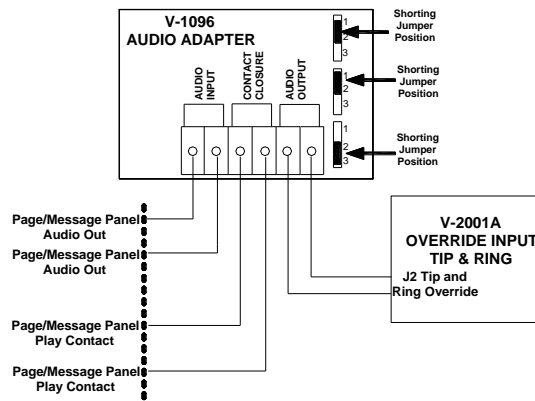

Figure 3: Connections to V-2001A Override Input

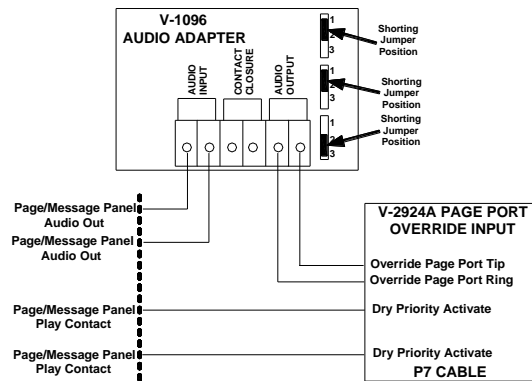
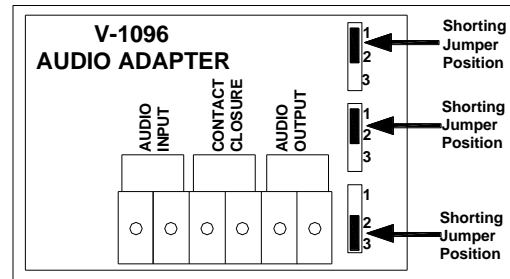

Figure 4: Connections to V-2924A Override Port



Default shorting jumper positions are shown. (From top to bottom – up, up, down). The only time that these need to be moved is when connecting the output of the V-1096 to a lo-z microphone input. In this case, all of the jumpers must be moved. (From top to bottom - down, down, up)

When the V-9908 is not directly connected to supervised speakers, a V-1096 Audio Adapter must be utilized.

- 1) Connect the audio output of the V-9908 to the audio input of the V-1096.
- 2) Connect the audio output of the V-1096 to the audio input of the receiving system. Examples of receiving systems include a tip/ring telephone input on a Valcom Page Control, the tip/ring audio input of one or more Valcom Self Amplified Speakers, a line level music or auxiliary input on a Valcom page control, IP Audio gateway or amplifier, or a lo-z microphone input. In the case of a lo-z microphone input, such as that found on Valcom MultiPath or Class Connection systems, all of the shorting jumpers must be moved from the default positions shown above.
- 3) If the audio input of the receiving system requires a “loop start” connection, then connect the message play contacts of the V-9908 to the Contact Closure input of the V-1096.

If the audio input of the receiving system requires an activation closure, then connect the message play contacts of the V-9908 to the activation input of the receiving system